

MAICO

Technical data, owners manual

MOTOCROSS 250 400 490 MODELL 1981

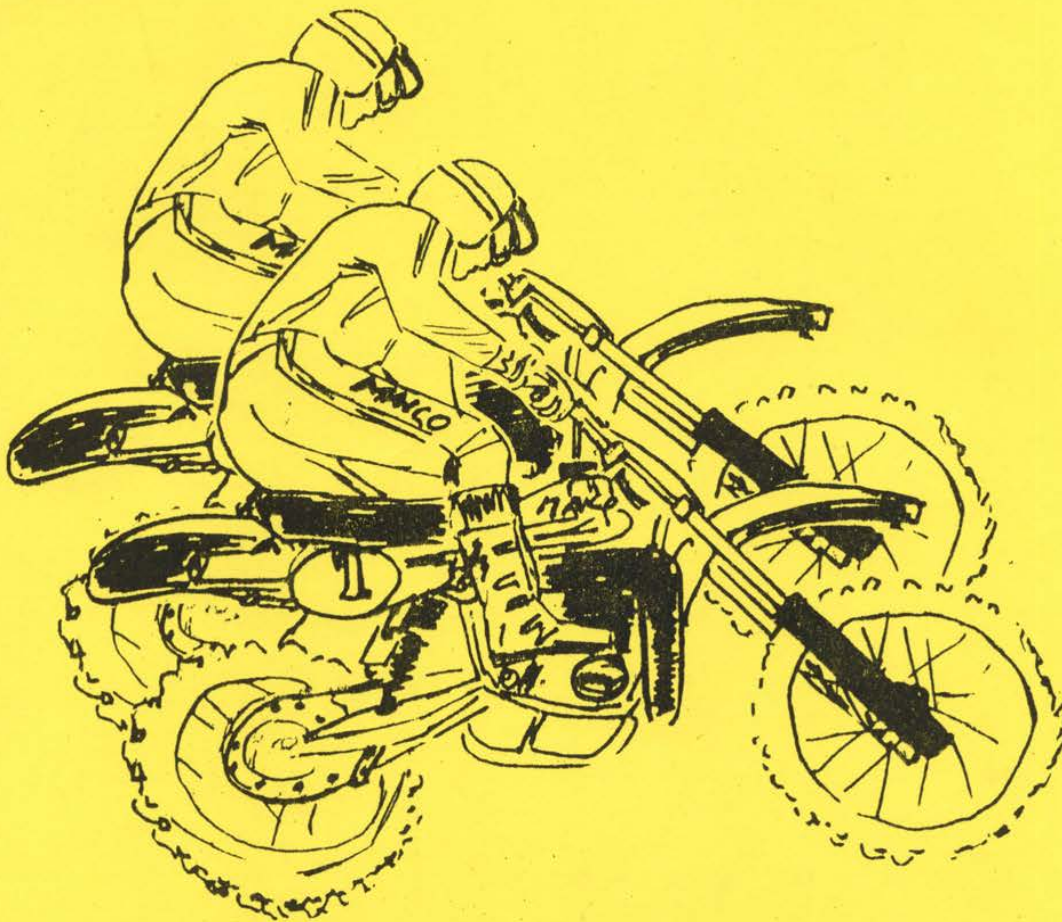

MAICO

FAHRZEUGFABRIK GMBH 7403 AMMERBUCH 2
TELEFON: (07073) 824/825 · TELEX 7262746

Made in West Germany

Instruction Manual MC 250, 400, 490

Contents

- 1.0 Preface
- 1.1 Description of machine
- 1.2 Service instructions
- 1.3 Starting and stopping the engine
- 1.4 First test run

- 2.0 Technical data
- 2.1 Fuel capacity
 - 2.1.1 Mixture ratio and fuel
- 2.2.0 Measurements, wheel travel, tyres
 - 2.2.1 Frame telescopic fork, swing arm, brakes
 - 2.2.2 Engine, piston, transmission, transmission ratio
 - 2.2.3 Ignition
 - 2.2.4 Carburetor
 - 2.2.5 Torque specifications

- 3.0 Chassis
- 3.1 Explosion chart chassis (frame)
- 3.2 Explosion chart chassis (fork, wheels)
- 3.3 Frame, swing arm, steering head
- 3.4 Air filter
- 3.5 Wheels, brakes, spokes
 - 3.5.1 Checking the brakes
- 3.6 Damping characteristics
 - 3.6.1 Telescopic fork, inspection, adjustment, assembly, disassembly
 - 3.6.2 Dampers
- 3.7 Exhaust system, silencers
- 3.8 Handlebars, fittings cables

- 4.0 Engine
- 4.1 Explosion chart engine
- 4.2 Parts description engine (clutch, transmission, cylinder, piston, piston rod)
- 5.0 Engine removal from the frame
 - 5.1.1 Repairs not requiring engine removal
 - 5.1.2 General remarks
 - 5.1.3 Engine removal
 - 5.1.4 Engine
 - 5.1.5 Disassembling the engine (disassembling succession)

- 5.1.6 Checking and maintenance
- 5.1.7 Checking the disassembled parts
- 5.1.8 General remarks
- 5.1.9 Assembling the engine
- 6.0 Ignition
- 6.1 Ignition chart
- 6.2 General remarks
- 6.3 Checking ignition timing
- 6.4 Timing
- 6.5 Spark plugs
- 7.0 Carburetor
- 7.1 Explosion chart
- 7.2 Technical data
- 7.3 Adjustment and jetting
- 7.4 Changing the cable
- 7.5 Changing the jets
- 7.5.1 Main jet
- 7.5.2 Needle jet
- 7.5.3 Pilot jet
- 8.0 Chain
- 8.1 Technical data
- 8.2 Chain tension
- 8.3 Cleaning the chain
- 8.4 Sprocket and pinion
- 9.0 Service instructions
- 9.1 Service instructions and repairing preparations
- 9.2 Tools
- 9.3 Special tools
- 9.4 Providing spare parts
- 9.5 Service instructions after 20 minutes run
- 9.6 Service instructions after one hour run
- 9.7 Service instructions after 10 hours run
- 9.8 Preparation for the race
- 10.0 Trouble diagnosis
- 10.1 Engine
- 10.2 Clutch
- 10.3 Transmission



1.0 Preface

Welcome to the MAICO-team in which we feel sure you will find yourself at home!

We thank you for your confidence in our products. Every motorcycle justifies this confidence by its brilliant technical quality achieved by experienced engineers. The machine has been assembled with the greatest care and accurateness, thereby guaranteeing the highest possible performance and maximum reliability.

The purpose of the following instructions and advise is to help you taking proper care for your motorcycle.

If you read this manual carefully you will surely enjoy your new MAICO.

MAICO-Fahrzeugfabrik GmbH

MAICO is not responsible for any damages caused by mistakes or uncompletenesses in this manual.

1.1 Description of machine

The MAICO machines MC 250, 400, 490 are especially constructed for competition use only. New characteristics of the chassis have been achieved by a new frame, a new telescopic fork and by new dampers according to the latest technical features. Thus the styling and the comfortable track handling of the old models have been considerably improved on the 1981 models.

The strengthened but still light-weight components make the 5-speed-engine famous for its stability. With the excellent transmission and a shifting to be handled easily the machine guarantees optimal riding features. The well-known two-stroke engines contribute to the unique power and performance increase which make these machines absolute top class bikes.



1.2 Operating instructions

1. Hand brake lever
2. Throttle grip
3. Clutch lever
4. Kill button
5. Decompression lever
6. Foot brake pedal
7. Kickstarter pedal
8. Gear change pedal
9. Fuel tank filter cap
10. Fuel cock
11. Shock absorber adjuster
12. Telescopic fork
13. Dampers
14. Chain tensioner
15. Chassis number
16. Engine number
17. Oil filter plug
18. Oil control screw
19. Oil drain plug

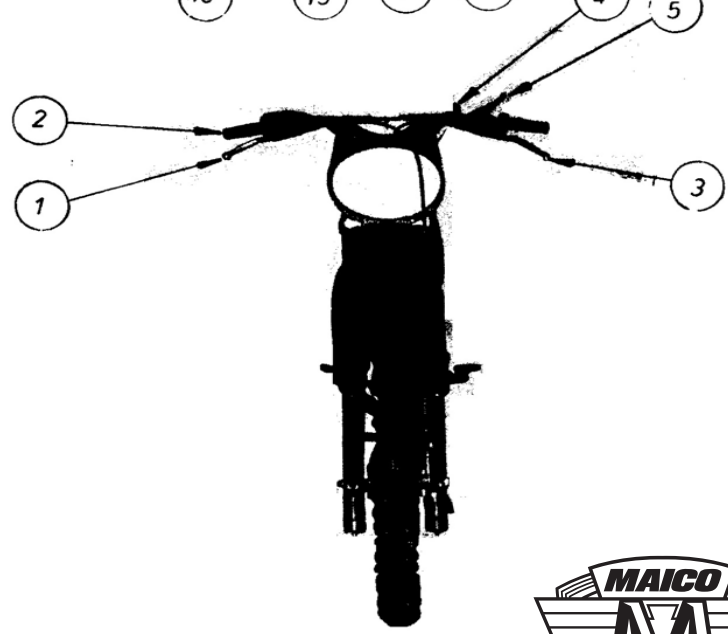
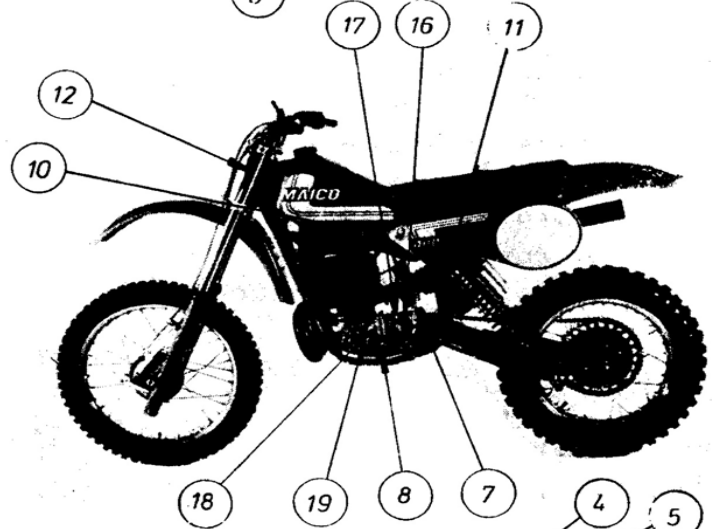
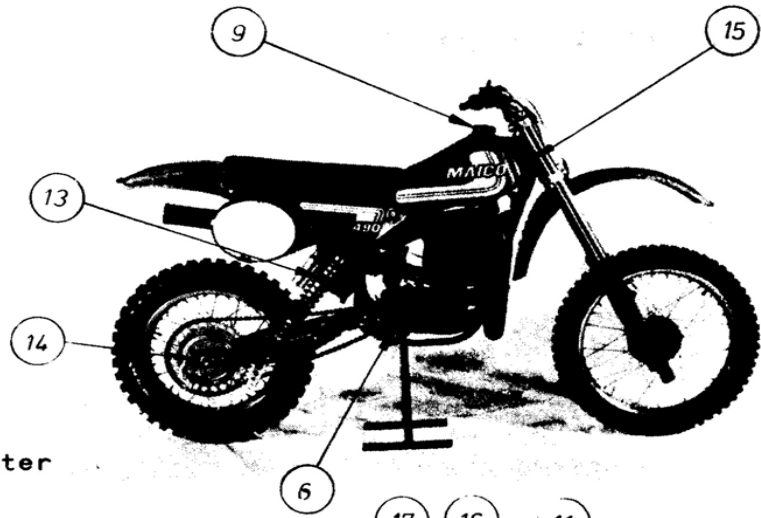

1.3 Starting and stopping the engine

- Caution: - check transmission oil level at the oil control screw
when the oil control plug is opened the oil has to flow out
- check spark plug for tightened position
 - oil foam filter if necessary
 - throttle grip has to move into starting position

Starting:

1. Open the pet cock
2. Flood carburetor until fuel comes out.
With starting engine use starting system by pressing down starting lever. When starting, throttle grip must be closed at any rate. Press up starting lever after 20-40 seconds running of engine
3. Shift transmission into neutral
4. Operate kickstarter by turning throttle grip at the same time
5. Go on until engine is running
6. After engine has started snap throttle grip 3-4 times shortly until engine is running properly.

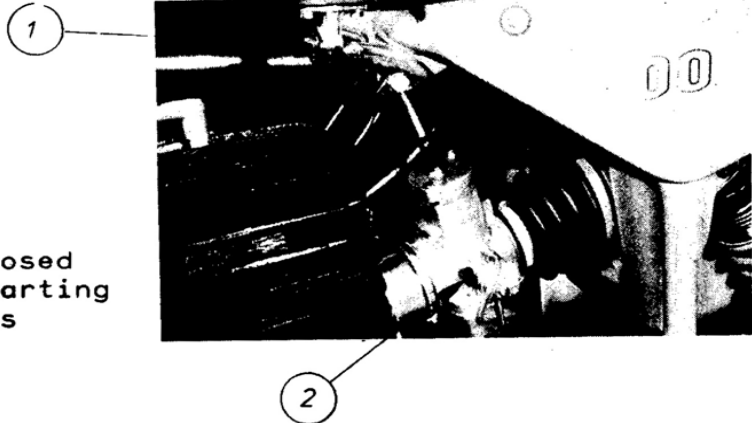

Stopping the machine:

1. Shift transmission into neutral
2. Close pet cock
3. Press in kill button when low revs.
4. Machine stops.

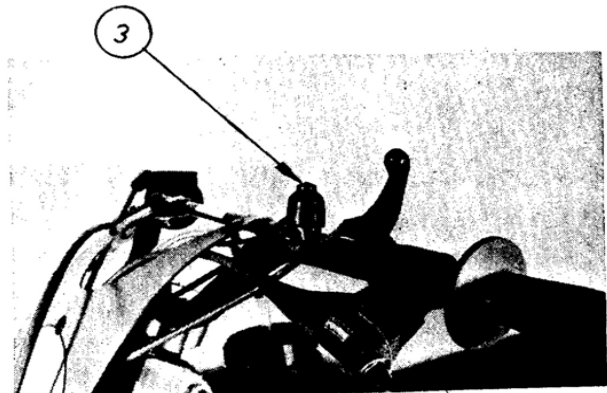

1.4 The first test run

Before the first test run move the measurements and the handlebars into usual position. Adjust the brakes as strong as you like them to be. If you start for your first test run be careful during the first 20 minutes, change gears carefully and run the machine in. Get used to the new track behaviour.

Check the brakes by using them several times to know exactly about the reaction of the machine:

Caution

For the services required after every run, please see chapter 9.0 Service Instructions.

2.0 Technical data

2.1 Fuel capacity

Oil for telescopic fork: about 535 cm³ hydraulic oil per leg HL 25, BEL RAY LT 100, LT 200

Oil for engine: 600 cm³ motor oil SAE 20 W-50 CHD or BEL RAY MC 4 light

2.1.1 Mixture ratio and fuel: special high quality oil mixture
1:20 with two stroke oil
1:50 with BEL RAY MC 1
1:100 with MAICO MC-GP-100 Mix oil

Caution: do never mix mineral oils and synthetical oils

Warning: Fuel is flammable and explosive under certain conditions. Always stop the engine and do not smoke near the motorcycle when refueling.



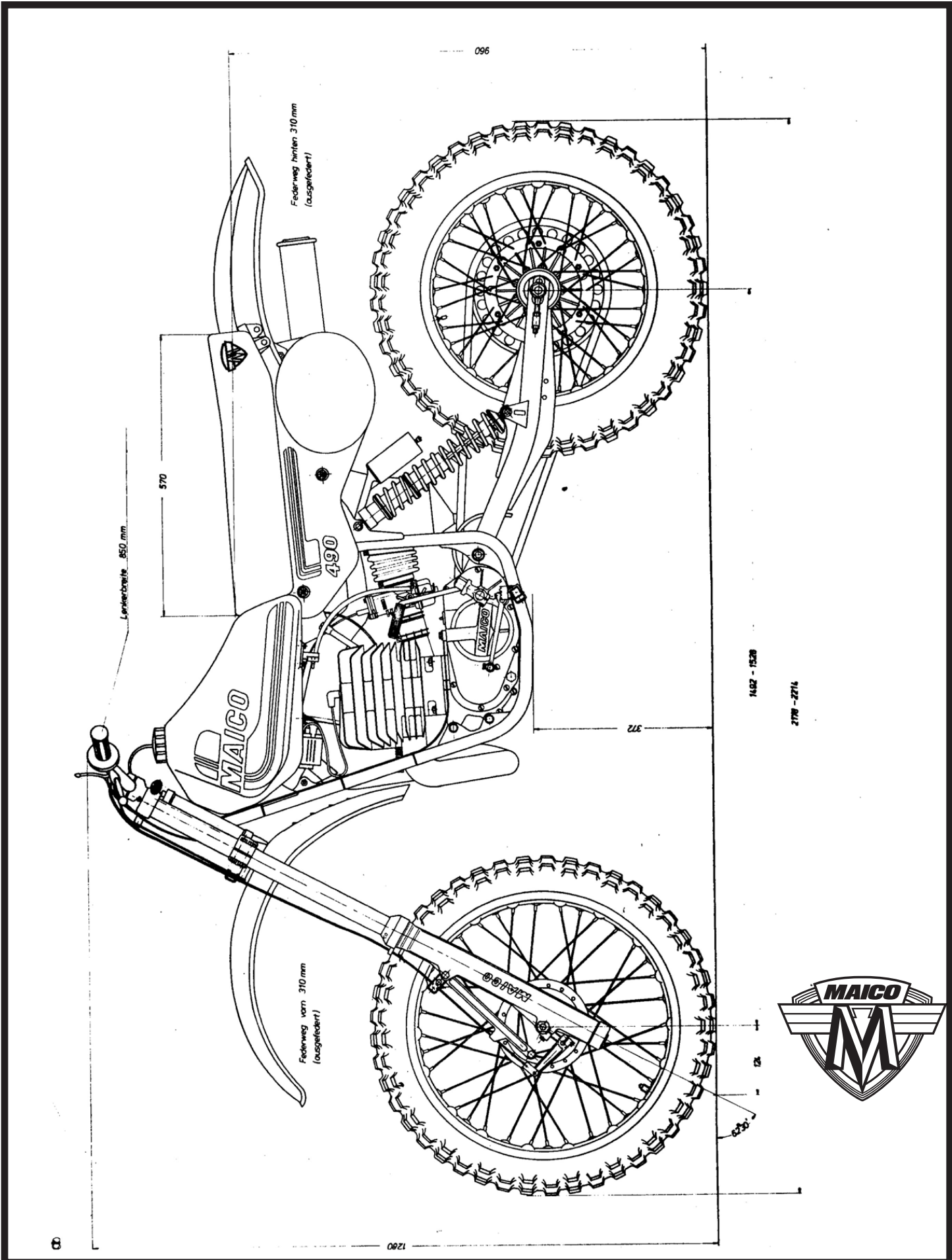

2.2.1 Frame, telescopic fork, swing arm, brakes

Frame: double loop chrome moly tubes (extreme light construction), tank tube triangle

Types:	MC 250 type 350	MC 400 type 351	MC 490 type 352
Total length:	2190 mm	dto.	dto.
Total width:	850 mm	dto.	dto.
Total height:	1290-1540 mm	dto.	dto.
Wheelbase:	60"	dto.	dto.
Seat height:	37,8"	dto.	dto.
Ground clearance	14,2"	dto.	dto.
Dry weight:	218 lbs.	222 lbs.	224 lbs.
Steering head:	covered roller bearings without clearance, adjust without tension		
Swing arm:	on needle bearings		
Wheel travel:	new Corte & Cosso compact dampers, adjustable and reparable		
Rear wheel travel:	310 mm		
Front suspension:	hydraulic telescopic air fork, 12,2" travel, Ø 42mm tubes		
Front brake:	drum 5,3" dia		
Rear brake:	drum 6,2" dia		
Front tyre:	3,00 x 21"		
Rear tyre:	4,50 x 18"		
Air pressure, front:	0,7-1,0 kp/cm ² (10-14 psi)		
Air pressure, rear:	0,6-0,9 kp/cm ²		
Fenders, air filter box:	unbreakable plastic		

2.2.2 engine

The piston oversizes varied from 0,20 mm part.

Measurement chart cylinder - piston

	250	400	490
piston	0,04-0,05 mm	0,06-0,07 mm	0,06-0,07 mm
std.	Ø 66.96 mm	Ø 76.95 mm	Ø 86.42 mm
1st over	Ø 67.16 mm	Ø 77.15 mm	Ø 86.62 mm
2nd	Ø 67.36 mm	Ø 77.35 mm	Ø 86.82 mm
3rd	Ø 67.56 mm	Ø 77.55 mm	Ø 87.02 mm
4th	Ø 67.76 mm	Ø 77.75 mm	Ø 87.32 mm
5th	Ø 67.96 mm	Ø 77.95 mm	Ø 87.42 mm



Cylinder should be rebored if excess piston play (about 0.04mm more than normal) and if excess ovality (max. tolerance 0.03mm).

	<u>MC 250</u>	<u>MC 400</u>	<u>MC 490</u>
Engine:	2-stroke, single cylinder, piston-port		
Bore/stroke:	67 x 70mm	77 x 83 mm	86,5 x 83mm
Displacement:	247 cc	386 cc	488 cc
Compression:	12 : 1	12 : 1	12 : 1
Horsepower:	40 HP/8000 (DIN)	47 HP/7000 (DIN)	53 HP/7000 DIN)
Max. Torque:	(3,7mkp)/6800rpm	(5mkp)/6200rpm	(5,2mkp)/6000rpm
Clutch:	oil bath clutch with 6 sindel metal clutch discs and 6 steel inner discs.		
Primary drive:	Duplex chain 3/8" x 7/32" chain parts		
Primary ratio:	41/18=2.28	39/21=1.86	39/21=1.86
Final drive ratio:	56/14=4.0		
Pinions:	12-14 teeth		
Transmissions:	5-speed gear-box, dog-shifting		

Transmission chart

MT1	1 gear	2 gear	3 gear	4 gear	5 gear	layshaft	sleeve	pinion
	MS	MS	MS	MS	MS			
	M19T	M21T	M24T	MG26T	MT28T			
	LS	LS	LS	LS				
	M126T	M123T	M21T	M19T		MT1 17T	MT28T	
RT1	MS	MS	MS	MS				
	G17T	G20T	R23T	MG26T	MT28T	MT117T	MT28T	
	LS	LS	LS	LS				
	G128T	G124T	M21T	M19T				

3rd and 4th gear on layshaft is a twin bloc
(MS=mainshaft, LS=layshaft)

The letters mentioned in above transmission chart in front of the teeth number are also stamped on the individual gear.



Shifting: with 3 shifting forks, shifting plate operates through shifting cam with engaged hooked ratchet. left foot operated.

Transmission ratio MC

Symbol and type:	MC 250 MT 1	MC 400 RT 1	MC 490 RT 1
1st gear:	2,25 (20,53)	2,71 (20,16)	2,71 (20,16)
2nd gear:	1,80 (16,43)	1,97 (14,66)	1,97 (14,66)
3rd gear:	1,44 (13,13)	1,50 (11,16)	1,50 (11,16)
4th gear:	1,20 (10,97)	1,20 (8,93)	1,20 (8,93)
5th gear:	1,00 (9,11)	1,00 (7,44)	1,00 (7,44)

() - overall ratios with $i_{sec} = 56/14$

Drive chain: 5/8" x 1/4", 114 links with lock

2.2.3 Ignition Motoplatt pointless ignition

Ignition timing: 1,6 ± 0,1 mm BTDC 2,1 ± 0,1 mm BTDC 2,1 ± 0,1 mm BTDC
Spark plug: Champion N2 or N2G (Bosch 280-310)

<u>2.2.4 Carburetor:</u>	MC 250	MC 400	MC 490
	∅ 38 mm	40 mm	40 mm
Slide:	2103	1201	220
Main jet:	195	185-195	185-190
Needle jet:	2,78-2	2,78-2	2,80-2
Pilot jet:	65	45	45-50
Jet needle:	6D2	8G2	6L2
Jet needle position:	2	2	2
Idler air screw:	1/2 or 1 turn over		
Carburation:	7	3	3



2.2.5 Torque Specifications

1. Crankshaft nut	M 25 x 1,5	196,2 Nm (20 kpm)
2. Clutch nut (on mainshaft)	M 12 x 1,5	68,7 Nm (7 kpm)
3. Magnet rotor nut	M 12 x 1 left	68,7 Nm (7 kpm)
4. Cylinder head studs	M 10	24,5 Nm (2,5 kpm)
5. Cylinder head nuts	M 8	24,5 Nm (2,5 kpm)
6. Cylinder base studs	M 8	19,6 Nm (2 kpm)
7. Cylinder base studs	M 8	19,6-24,5 Nm (2-2,5 kpm)
8. Shifting mechanism detent bolts and cam guide bolts	M 14 x 1,5	24,5-29,4 Nm (2,5-3 kpm)
9. Crankcase cover screws(not applied on the right hand crankcase cover)	M 6	8,8 Nm (0,9 kpm)
10. Armature plate screws	M 5	4,9 Nm (0,5 kpm)
11. Engine mounting x bolt	M 8	24,5 Nm (2,5 kpm)
12. Engine yoke	M 8	24,5 Nm (2,5 kpm)
13. Front axle	M 14 x 1,5	39,2 Nm (4,0 kpm)
14. Swing arm nut	M 14 x 1,5	63,8 Nm (6,5 kpm)
15. Rear axle nut	M 16 x 1,5	73,6 Nm (7,5 kpm)
16. Dampening rod bolts	M 10	19,6 Nm (2 kpm)
17. Steering head nuts,	M 27 x 1	playfree	
18. Pinch bolts for the fork tubes	M 10	39,2-44,1 Nm (4-4,5 kpm)
19. Front axle pinch bolts	M 6	8,8 Nm (0,9 kpm)
20. Front brake backing plate	M 8	19,6 Nm (2 kpm)
21. Rear brake backing plate	M 10	39,2 Nm (4 kpm)
22. Rear brake backing plate	M 8	19,6-24,5 Nm (2-2,5 kpm)



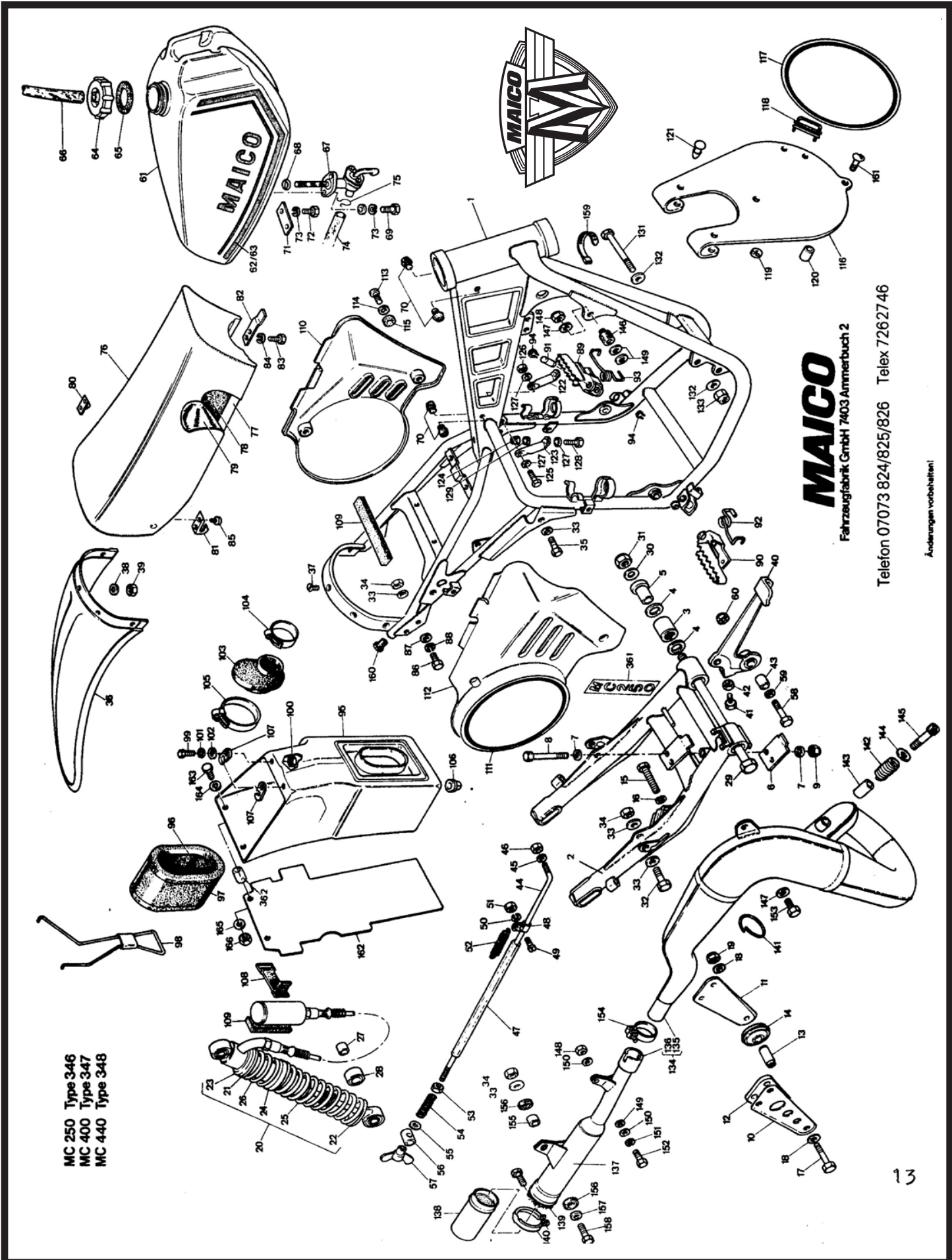

MC 250 Type 346
 MC 400 Type 347
 MC 440 Type 348

MAICO

Fahrzeugfabrik GmbH 7403 Ammerbuch 2

Telefon 07073 824/825/826 Telex 7262746

Änderungen vorbehalten!

3.2. Explosion chart chassis (fork wheel)

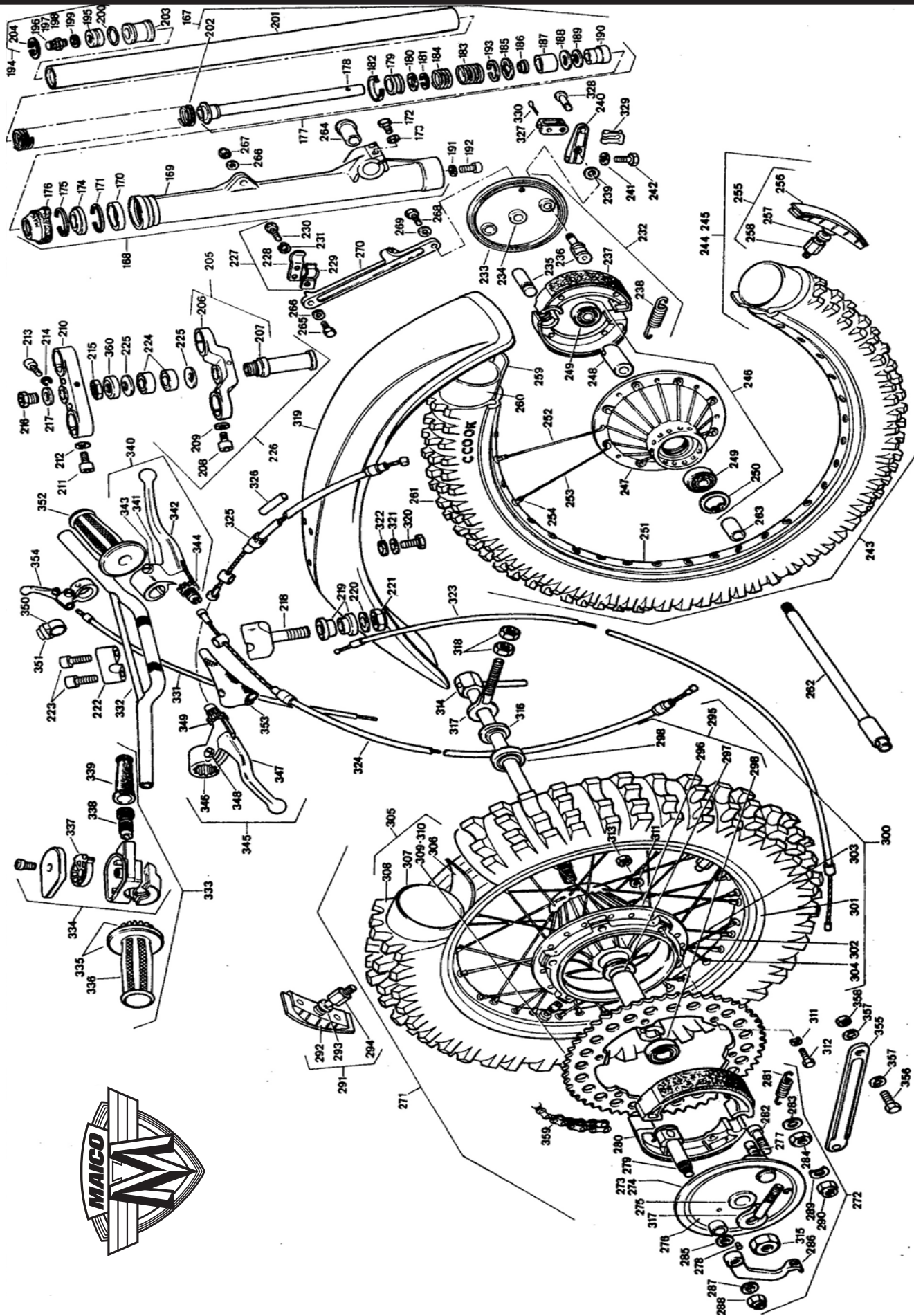

3.3 The Frame

The frame of the MAICO models 1981 is made of double loop chrome moly. The steering head has been lowered slightly, so that the driving characteristics and the good handling of the machine could be improved.

Servicing the steering head

Disassembly:

1. Disassemble telescopic fork (see chapt.3.6.1)
2. Remove handlebars (s.chapt.3.8)
3. Remove number plate and front fender
4. Open pinch bolt
5. Loosen steering tube nut
6. Pull upper cross head upwards
7. Loosen steering head nut and screw it out
8. Pull out lower cross head with steering tube
9. Check the ball bearing
10. Check the surface of the bearings in the frame.

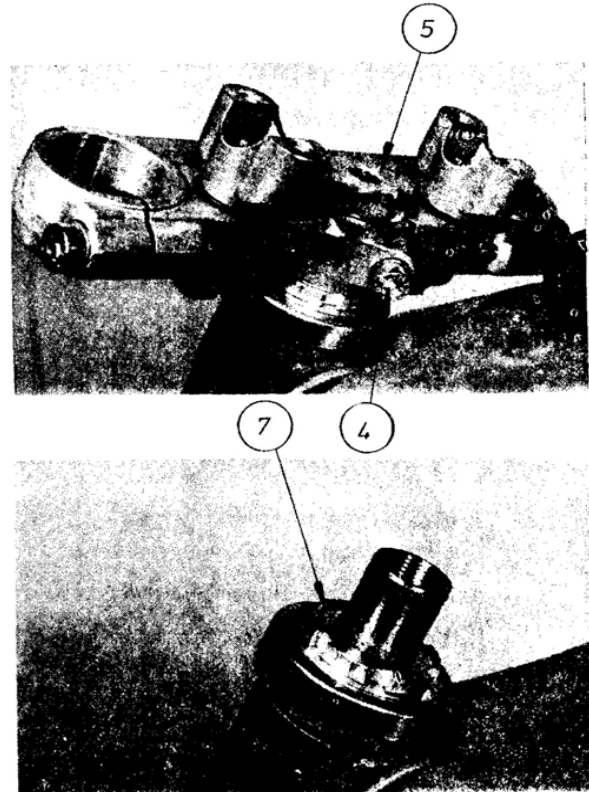

How to renew the bearings

1. Knock out bearings with hammer and iron bar
2. Press in new bearings with tools under a press
3. Pull out lower steering head bearings and push in the new bearings.

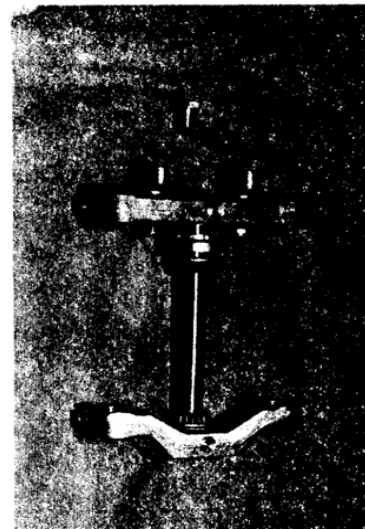

Assembly

1. Grease bearings properly
2. Insert lower cross head with steering tube into steering head.
3. Push upper bearings onto steering tube
4. Apply top of bearings
5. Tighten steering head nut without pretensioning.
6. Insert upper cross head
7. Tighten steering tube nut
8. Tighten clamp screw.

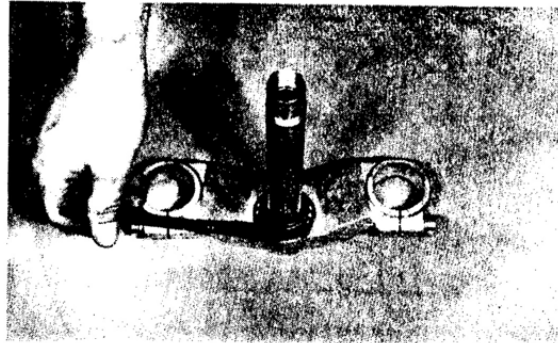

The swing arm

The swing arm is made of double loop chrome moly with a thickness of 2 mm. Swing arm length is 560 mm.

Disassembly of the swing arm

1. Remove the rear wheel (see chapt. 3.6)
2. Loosen shock absorber holders left and right
3. Remove gas shocks
4. Open axle for swing arm and pull it out.
5. Now swing arm can be pulled out.

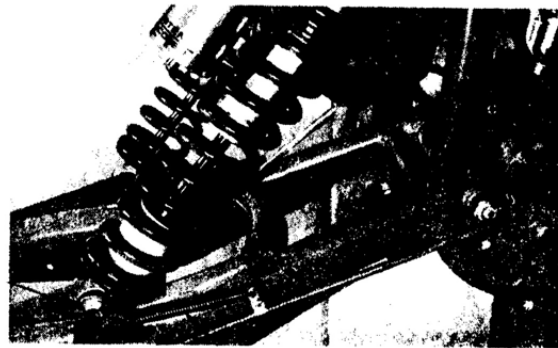

The swing arm has to be inspected now and then.



Greasing needle bearing

1. Press out bush for rear wheel swing arm
2. Take out o-ring
3. Clean needle bearing carefully
4. Grease needle bearing
5. Insert o-ring

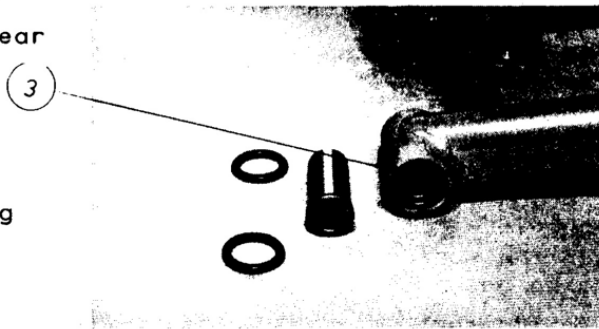

6. Grease bush

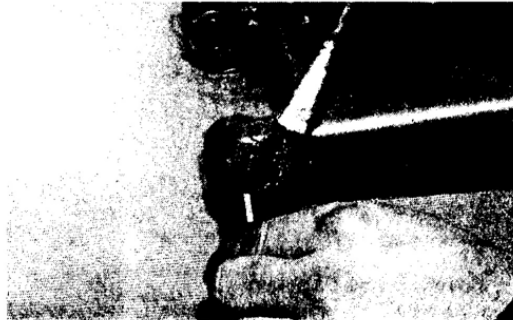

7. Press bush in.



Renewing chain guide

1. Open screw
2. Pull out screw
3. Exchange upper and lower chain guide
4. Push in screw
5. Tighten screw

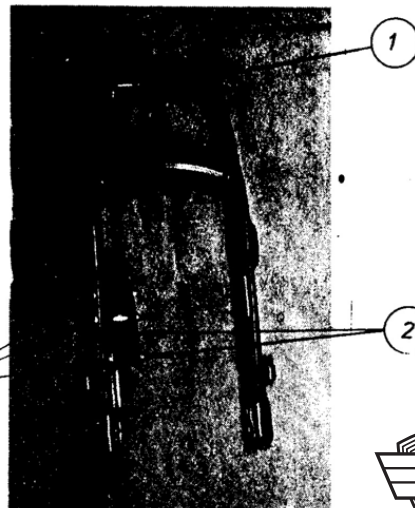

Renewing guide rollers and plastic plate

1. Open screws
2. Replace guide rollers and plastic plates on chain guide
3. Tighten screws again.



3.4 The air filter

The air filter consists of an air filter foam and an air filter cage. The air filter has to be checked before every race and be cleaned and oiled if necessary.

Disassembling the air filter

1. Loosen the screws for seat mounting hook
2. Remove the seat

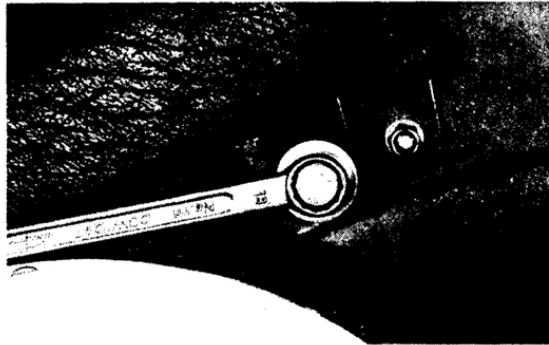

3. Loosen the holding wire
4. Take filter out

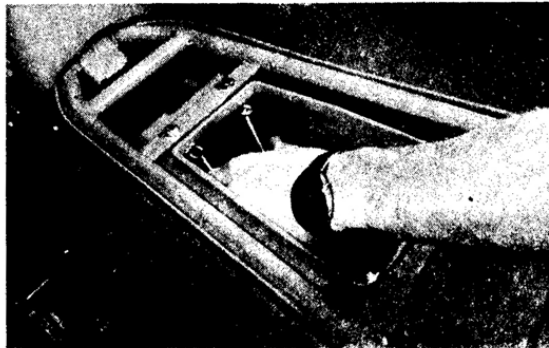

5. Remove foam plastic from air filter cage
6. Wash foam plastic in clean solvent and press it out
7. Oil filter with gear oil SAE 20 or BEL RAY MC6 and press out the oil. Thin oil is dripping out of the filter. Air filter oil or very thick oil, thinned by Chlorothene, is better. (All air filter oils are mixed on that base.)
8. The connecting surface has to be slightly greased. Before reinstalling the air filter should be cleaned and the density of the intake manifold between carburetor and air filter box should be checked.
9. Now put the filter element onto the flange.
10. Close the holding wire
11. Fix the seat. Be sure that the front clamp holder of the seat is pushed under the cross connection of the frame.

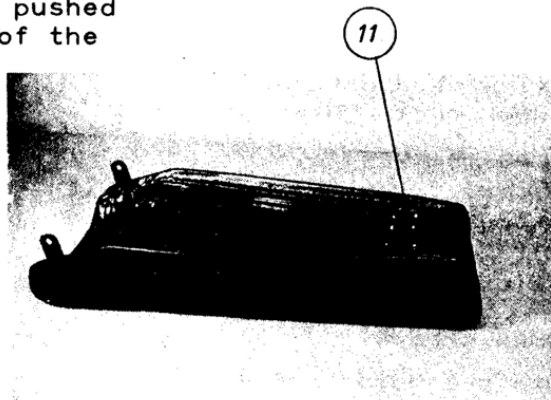

3.5 Wheels, brakes and spokes

The front wheel

Its \emptyset is 21". It consists of a light metal rim and light metal hub. An iron brake drum with 136 mm \emptyset is inserted into the hub.

The rear wheel

Its \emptyset is 18". It consists of a light metal rim and a light metal hub. An iron brake drum with 160 mm \emptyset is inserted into the hub.

The tyres: front: 3.00 x 21"
 rear: 4.50 x 18"
 or: 5.00 x 18"

The front brake plate is made of magnesium. The diameter of the brake shoes is 136 mm. The brake shoe thickness is 25 mm. The rear brake plate is made of aluminum and of an aluminum cover plate. The diameter of the brake shoes is 160 mm. Brake shoe thickness is 30 mm.

Disassembling the front wheel:

1. Place a support block under the machine and raise the front wheel off the ground
2. Loosen brake rod
3. Loosen nut
4. Pull out split pin and disconnect brake cable
5. Loosen clamps at both sides
6. Screw out axle and pull it out
7. Wheel is disassembled

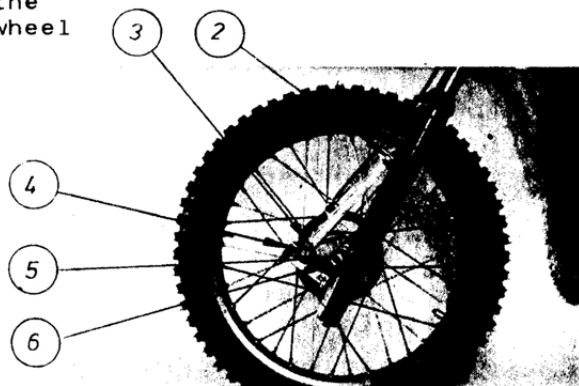

Inspection:

1. Check wheel bearings for play and sealing
2. Clean front brake plate thoroughly
3. Clean if necessary brake drums with a steel brush and check if there is still enough brake shoe lining.

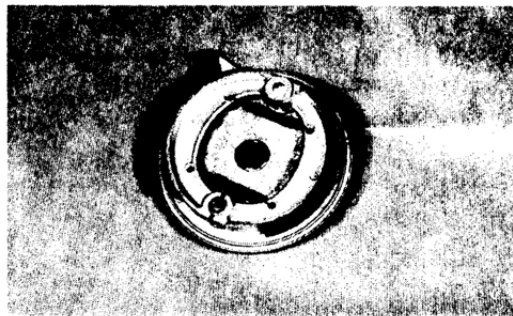

4. Now take the brake linings off the brake plate.



5. Check whether brake toggle can be easily turned
6. If brake toggle is difficult to turn open the nut and take off brake lever and brake key
7. Clean brake toggle and bore thoroughly and grease slightly with BEL RAY MC11 before assembling
8. Clean brake drum with dilution or BEL RAY-cleaner. Clean inner rings of wheel bearings.
9. Reassemble brake plate in reverse order

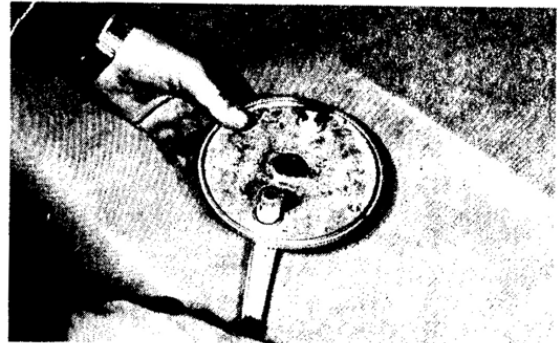

Caution: Do not distort brake shoes and brake toggles when assembling. The best is to mark them before disassembling with a coloured pen.

Assembling the front wheel:

1. Before assembling the front wheel axle grease and clean it
2. Insert brake plate into hub
3. Place front wheel with brake plate between the fork and put through the front wheel axle. Don't forget the spacer. Now tighten the axle slightly
4. Hang in the cable and secure it with split pin
5. Tighten brake rod
6. Slightly tighten the brake axle at the brake plate.

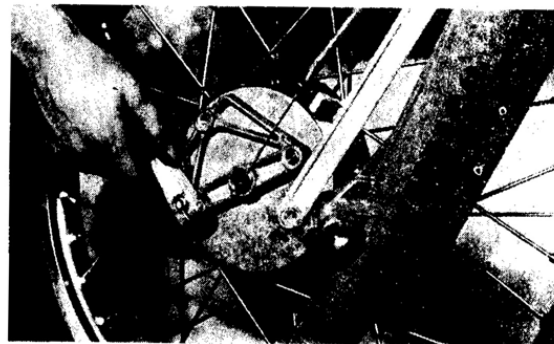

8. Slightly turn the wheel
9. Pull the front brake thoroughly
10. Tighten brake rod at brake plate
12. Loosen brake
13. Tighten clamps for front wheel axle on both sides and be careful when tensioning the telescopic fork

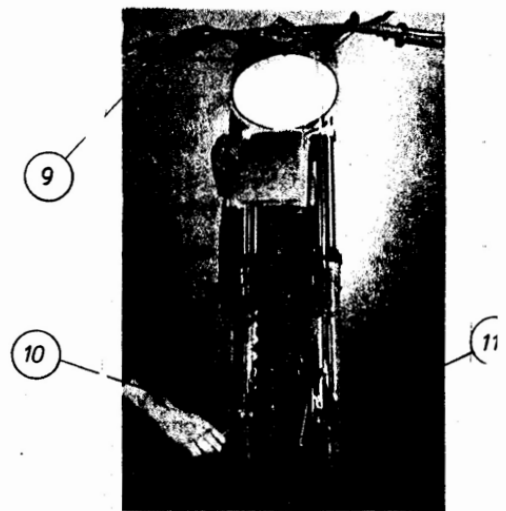

Inspecting the spokes

The spokes also have to be checked. All spokes must be undamaged. A damaged spoke must at once be replaced by a new one. In intervals of 1-1,5 hours the spokes have to be tightened up. The spoke nipples must be greased before tightening. We are recommending BEL RAY MC 22, so that the spokes can be tightened easily.

Disassembling the rear wheel

1. Place the motorcycle into such a position that the rear wheel is off the ground
2. Screw out the nut and remove the brake rod
3. Loosen the axle nut and pull out the axle

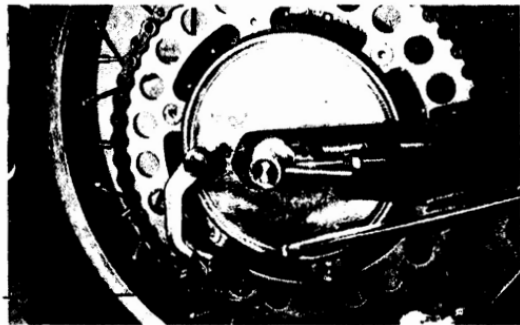

4. Take the chain of rear sprocket and pull out the wheel.

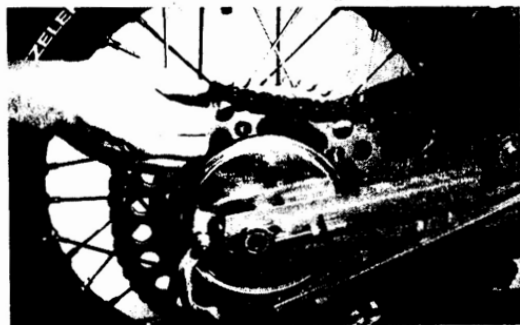

Inspection

1. Check wheel bearings for play and sealing
2. Clean brake plate thoroughly
3. Clean brake drums if necessary with a steel brush and check if there is still enough brake shoe lining.
4. Now take the brake shoes off the brake plate (see picture front wheel) and check the brake toggle for easy turning.
5. If brake toggle is slowly moving, open the nut and remove brake lever and brake key. Clean brake toggle and bore thoroughly and grease slightly before assembling. We recommend BEL RAY MC 11 or Molykote.
6. Clean brake drum with dilution or BEL RAY-cleaner. Clean inner ring of wheel bearings.
7. Reassemble brake plate the reverse order.

Caution: Do not distort brake shoes and brake toggles when assembling. The best is to mark them before assembling with a coloured pen.

Inspecting the spokes: (see front wheel)

Inspecting the sprockets:

After a run of 1-1,5 hours tighten all six nuts at rear sprocket. Do not forget to tighten the securing nut.

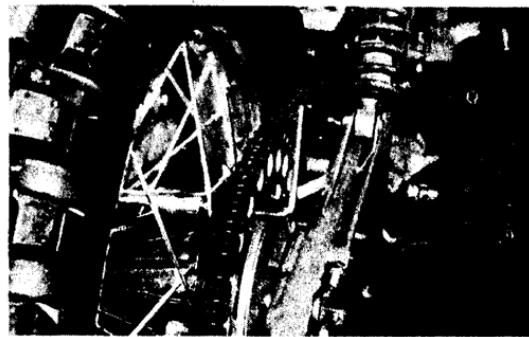
Assembling the rear wheel:

1. Insert brake plate into hub
2. Insert rear wheel with brake plate into swing arm and pay attention so that the brake rod is within the chain guide.

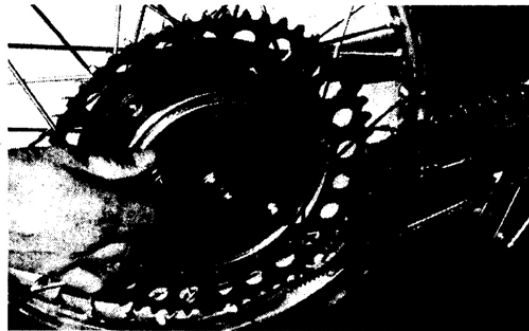

3. Adjust the chain
4. Insert the axle

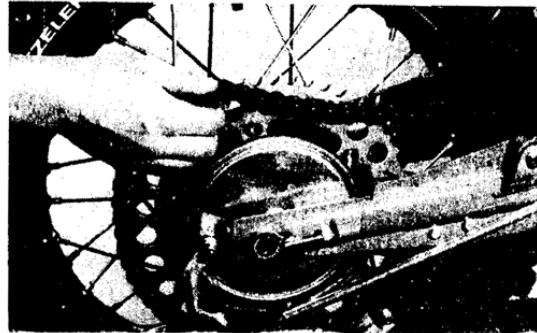

5. Insert the spacer
6. Slightly tighten the axle nut

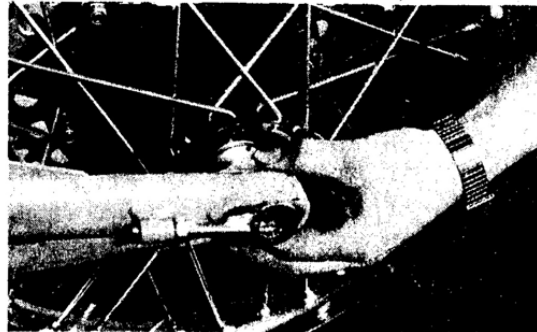

7. Check the chain tension. It must not be possible to press the chain higher at where it is pressed with the fingers.

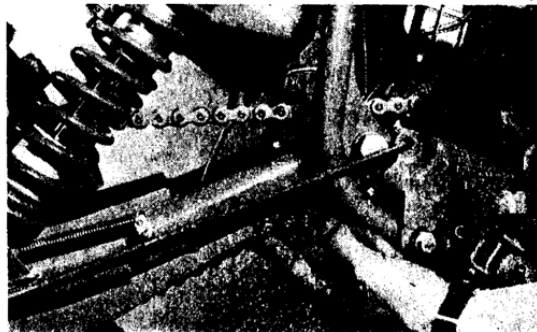

8. If chain is too tight or too loose it has to be adjusted properly. Loosen securing nut at both sides and adjust the correct chain tension. Tighten securing nut afterwards. When tensioning the chain pay exact attention to the chain alignment.

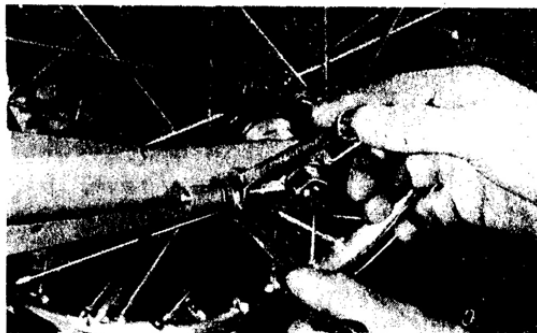

9. Hang in and adjust brake rod
10. Turn the wheel and use the brake
11. Tighten the axle nut
12. Don't loosen brake before axle nut is tightened.



3.5.1 Front brake adjustment

Adjusting the front brake

1. Major adjustments should be made at the rear brake lever. The lower brake lever must be adjusted onto the tooth system of the brake toggle so that it is located in a vertical position (90°) to the brake cable.
2. Minor adjustments can be made with the front brake cable adjuster at the upper brake lever. This should be adjusted so that the working point is about at half pulled brake lever.

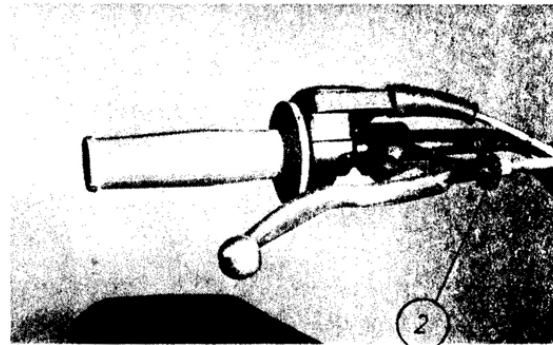
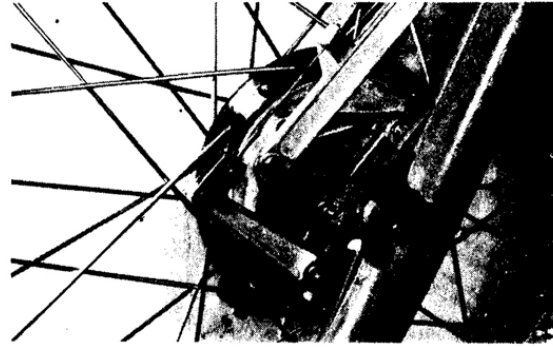

Adjustment

1. Take off the cap
2. Loosen the security nut
3. Adjust the wanted effect
4. Tighten security nut
5. Close the cap

Adjusting the rear brake:

1. Major adjustments should be made at rear brake lever. The rear brake lever must be adjusted onto the tooth system of the brake toggle so that it is located in a vertically position to the rear brake cable.
2. Minor adjustments can be done at the rear nut.

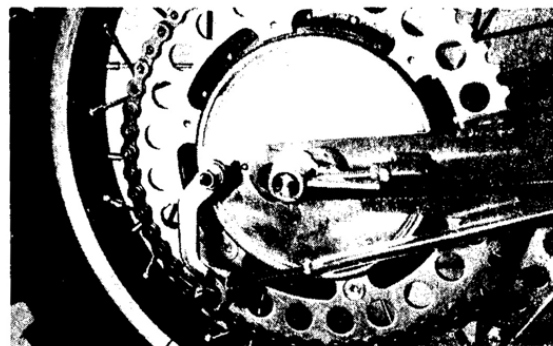

2



Adjusting

1. Turn the adjusting nut on individual brake pedal position.
2. Rear brake pedal free play should be maintained at 2-3 cm. It is measured at the nut of the brake cable.

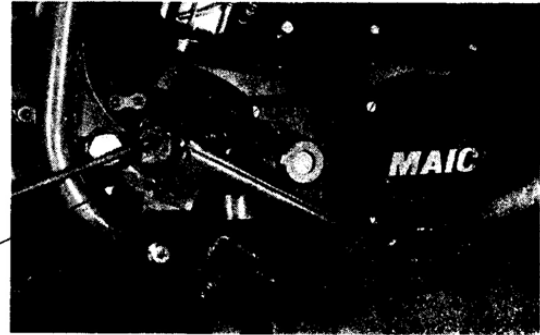

3.6 Dampening characteristics

3.6.1 The telescopic fork

Fork tubes are made of ϕ 42 mm fork sliders with 2 seals and removable guide bush. Fork travel 310 mm, progressively operating dampening unit with linear wound springs. Linear wound spring is assisted by compressed air (1 atü - 14 psi) oil capacity of 570 cm³ per leg. Proper oil level should be measured 16 cm from the upper edge of the fork tube. Measurement should be made without spring. Fork should be fully compressed.

Adjustment

Oil capacity and air pressure can be varied depending on body weight and track conditions. (\pm 20 cc oil volume, \pm 0,2 atü - 2,8 psi air pressure).

Telescopic fork - characteristics	oil	air pressure
harder fork	much	much
progressive fork	much	normal
hard working fork	normal	much
normal fork	normal	normal
soft progressive fork	normal	little
soft progressive fork	little	normal
very soft fork	little	little

These fork characteristics make it possible for the client to adjust its fork individually. The combinations result of scientific considerations and have been confirmed in many tests by our work riders.



The fork oil

Naturally the viscosity of the fork oil must be appropriate to the present temperature.

Therefore we recommend:

- 10° - + = BEL RAY LT 100
- + 15° - + = BEL RAY LT 200

Inspections

1. Check fork slider for density at radial seal ring.
2. Check fork slider for scratches at axle suspension. Those are caused by wrong tightening of clamp nuts.
3. Check fork slider for damage by falling stones. (Fork suddenly gets stuck and can't be operated any more.)
4. Check the valve in the front plug for density.
5. Chrome-cover of fork tubes must be optically controlled.

Service not requiring fork removal

1. Air controlling and refilling
2. Oil refilling
3. Tensioning fork spring more or less
4. Changing the springs.

For such services the handlebar has to be removed (s. chapt. 3.8).

Service not requiring fork removal

1. Exchanging fork tubes
2. Exchanging fork slider
3. Exchanging oil
4. Service at damper tube
5. Changing radial seal ring
6. Changing fork wiper

Disassembling the fork:

1. Disassemble the front wheel (see chapt. 3.5)
2. Loosen clamp nuts at cross heads
3. Turn fork slider into one direction and pull it out downwards



Disassembling the fork

1. Screw off the valve cover and let off the air
2. Remove circlip with a pair of circlip tongs
3. Press out fork cap by pressing together the fork slider
4. Pull out spacer bush and spring
5. Turn over fork slider and drain the oil into a special container
6. Open the inner hexagon screw and screw it out
7. Pull main tube with damper tube carefully out of fork slider
8. Pull damper tube cover off camper tube. Turn over main tube and let damper tube glide out
9. If main tube is changed don't forget to take the valve, the valve seat and the damper insert out of main tube. When assembling a new main tube don't forget mounting of circlip for valve seat.

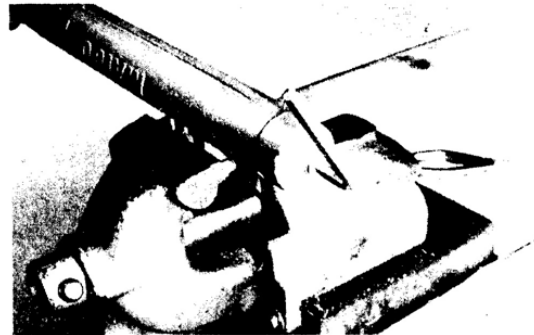
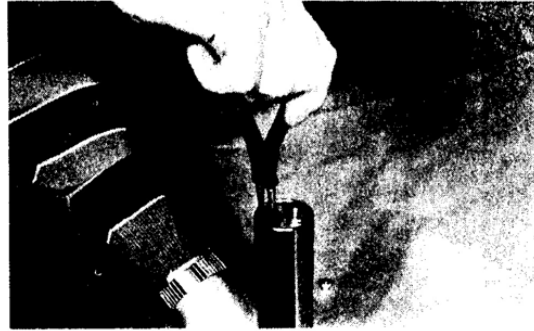
Inspection of the assembled parts

1. Check whether main tubes are eventually bent
2. Push main tubes through fork slider and check whether they are sliding through properly
3. Control damper tube for scratches. In case of a damage mentioned under 1-3, the damaged part must be replaced by a new one.

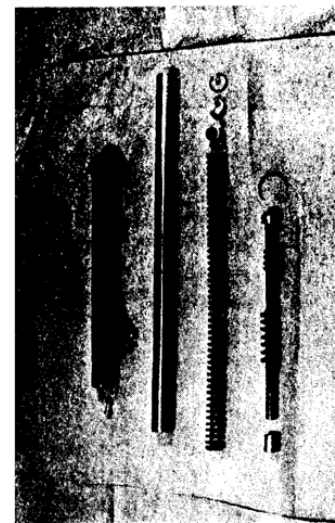

Changing the radial seal ring

1. Take off the fork wiper
2. Remove circlip with circlip
tongs and a screwdriver
3. Press out radial seal ring
with a crowbar. Thereby
be careful not to damage the
connecting surface at the
fork slider.
4. Clean the surface fatfree
5. Press in new radial seal
at a press by special tools
6. insert circlip
7. Grease radial seal ring

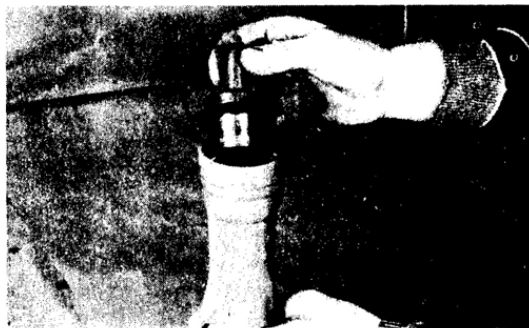
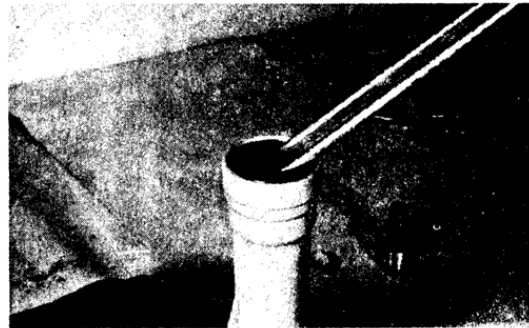
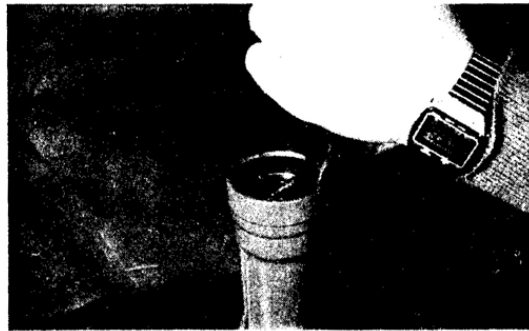

Assembling the fork

1. All parts must be cleaned
properly before assembling
2. Push in damper tube with
stop-springs and damper
piston ring downwards
into the fork tube
3. Insert bush for damper when
damper tube sticks out of
fork tube
4. Carefully insert damper tube
with fork tube into fork slider.
Be careful not to damage radial
seal ring.



5. Tighten damper tube at the base of fork slider with inner hexagon screw
6. Now fill in the oil (530 ccm). We recommend BEL RAY LT 100 or LT 200. Pay attention to the temperature-table (p.26) and fill in the necessary oil according the outside temperature
7. Insert spring and spacer tube
8. Press in fork cap and secure with circlip
9. Fill in air
10. Screw on valve cap



Assembling the fork

1. Push in fork leg by turning it into one direction
2. Tighten clamp screws at the cross heads

3.6.2 Shock absorbers

The shock absorbers of the machine are Corte & Cosso gas shocks with reservoir. Their installation length is 385 mm.

Bore of the piston rod is 125 mm. The rear shocks consist of 2 springs, a short one with a thickness of 7,5mm, and a long one with a thickness of 8,6 mm.

The bearing of the rear shocks are 2 silent-blocs.

Inspection

1. Check rear shocks for density
2. Check whether colour of piston rod has changed from yellow to blue
3. Check whether piston rod is bent

Disassembling rear shocks:

1. Place the motorcycle on a support
2. Screw out nuts at shock absorbers

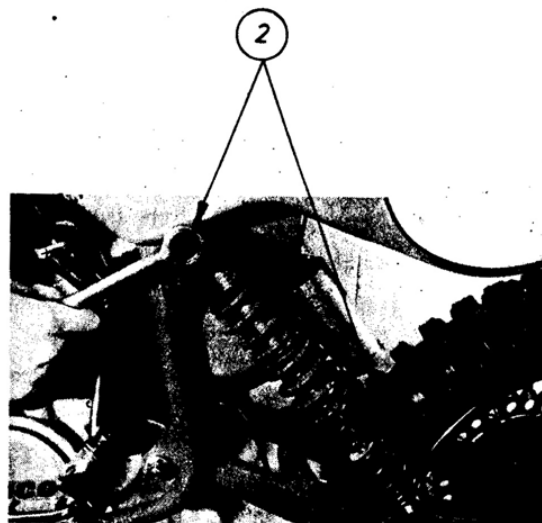

Disassembling the spring for rear shocks

1. Clamp the shock absorbers into a vice
2. Push the impact rubber near to the shock absorber case
3. Press down spring with a screwdriver and pull out spring holder plates

CAUTION: Screwdriver is slipping off easily. (don't damage piston rod)

4. Take out springs for rear shock

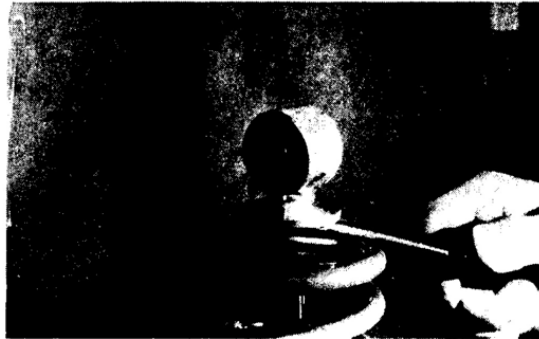

Inspection of shock absorbers

1. Is piston rod bent
2. Is shock absorber working normally when piston rod is pressed in
3. Is piston rod coming out again by itself and within what time. Normal time is 2-3 seconds
4. Are both shock absorbers working equally
5. Is the case damaged very much
6. Are the bushes deflected
7. Has the pressure rod much side play



In case one of these failures should show off, the shock absorbers must be replaced.

Assembling the rear shocks

When assembling the rear shocks you should be two persons. At first you put the supporting elements, then the short spring then the adjusting element and finally the long spring onto the shock absorber case. Now one of you has to pull the long spring downwards with both hands, so that the other one can push in the security plate.

Assembly

Assembly is the reverse order of removal. When assembling pay attention so that the spacer bush with collar is in the upper damper eye. The collar must be at the side where the welt nut is inserted, that means in the direction of the inner part of the machine.



The preload

The springs should be preloaded in such a way that the shock absorbers are almost rebounded when the motorcycle is standing free. The motorcycle should hang at the most 1-2 cm in the suspension

The preloading

Preloading the rear shocks is the same as disassembling the shock absorbers. When the springs are removed the circlip must be set one groove further and thus more pretension is reached. Naturally this must be done at both shock absorbers.

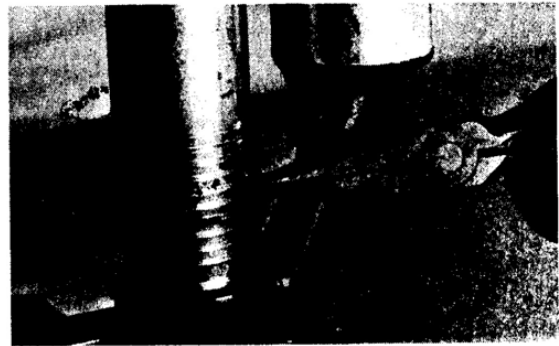

Maintenance and Disassembly Procedure

This procedure is meant for the maintenance, the disassembly, the assembly as well as for the changing of the damping adjustment with a special Corte & Cosso component.

CAUTION: The operation should be carried out with the same sequence.

Disassembly

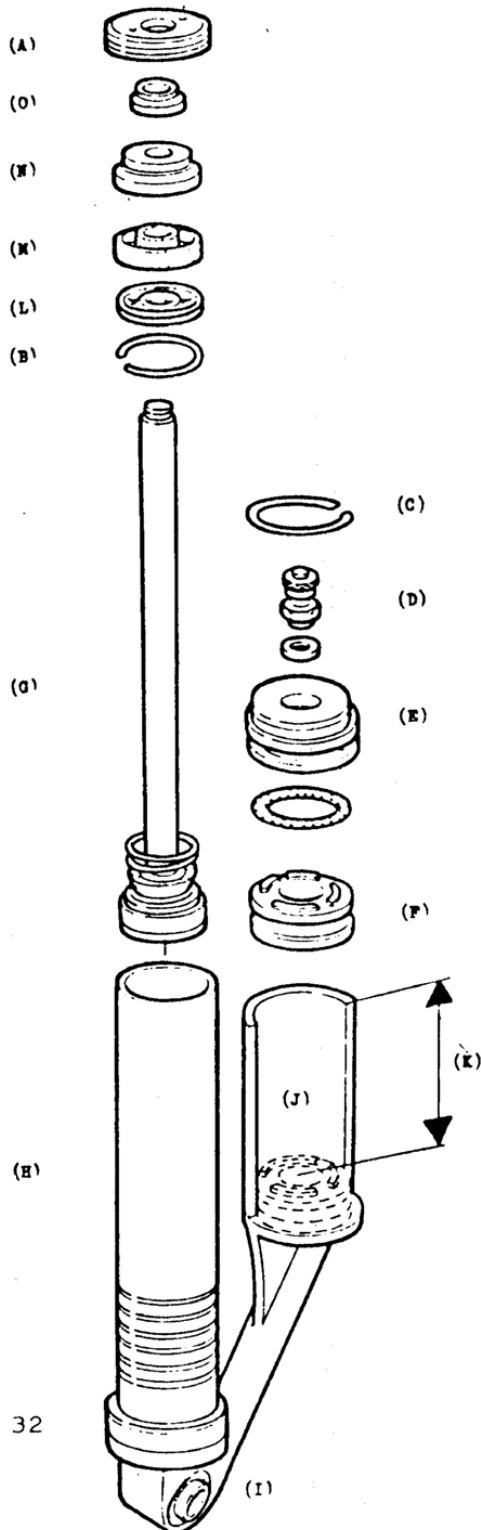

1. Place the shock absorber in the vice
2. Compress the spring and remove the upper retainer and springs carefully
3. Discharge the gas from the reservoir by pressing the valve
4. Hold the shaft in a vice with brass or aluminum against the jaws of the vice
5. Unscrew the upper eye
6. Remove the valcolan pad (bumper)
7. Remove the pad bearing washer
8. Shaft must be now vertically positioned in the vice
9. Push the shaft into the main body quickly
10. Now the shaft should be raised slowly
11. Unscrew the locking cap (A)
12. The shaft assembly must now be removed quickly from the main body up to the point of contact with ring bearing (circlip) (B)
13. Lower again the shaft to leave one or two centimeters below the ring bearing
14. Detach the ring bearing (B) with a small screwdriver. Do not damage the surface of the inner wall of main body
15. Remove the ring bearing (B) from the main body
16. Remove the shaft assembly
17. Empty the oil from the main body
18. The reservoir plug should be pushed in until the circlip surface
19. Remove the locking ring (C) from the reservoir
20. By holding the valve stem (D) with a pliers the reservoir plug can be removed
21. Again using external pliers (tweezers) remove the floating piston (F) or blow air in the main body to remove the piston
22. All the components should be washed carefully in a solvent. Use only cleaning solvent. Any other solvent could damage the rubber components.



Assembly Operations

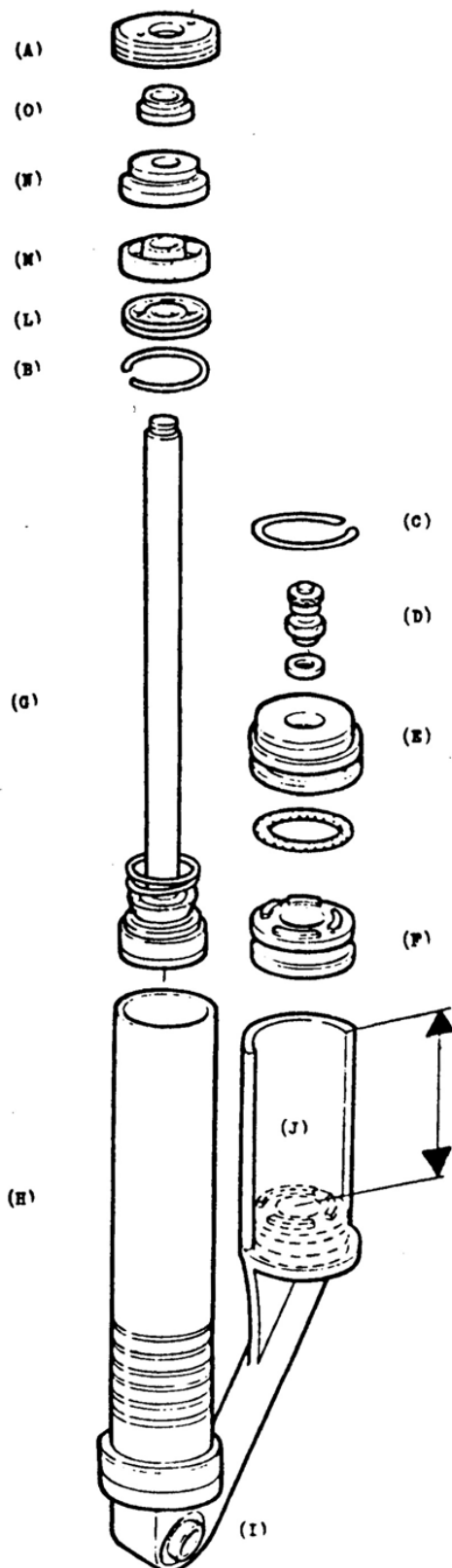

NOTE: The main body should be vertically positioned in the vice during the assembly procedure.

1. Choose the complete piston and valve assembly with desired setting (G)
2. Insert the complete piston rod into the main body (H)
3. The ring bearing (circlip) (B) should be located in the groove in the main body
4. Insert the piston and shaft assembly into the main body
5. Fill the reservoir with oil (J)
6. Insert the floating piston (F) into the reservoir. Do not leave the air gap in between the piston and oil
7. Using a screwdriver push the floating piston into the body to a depth of 60mm (K)
Caution: During this operation the piston rod must be firmly seated on the bottom of the main body.
8. The main body should be filled with oil to cover until the ring bearing (circlip) (B)
9. Insert the shoulder plate (L) on the piston rod
10. Assemble the gasket (M) and the piston rod guide (Caution should be given when installing the gasket seal. Do not damage the gasket lip)
11. Push the gasket and the piston rod guide to be in contact with the shoulder plate
12. Insert the dust control ring (O) on the shaft
13. Screw the locking cap (A) in the main body (do not locktite the threads)
14. Insert the locking reservoir plug (E) and push it down to a position below the lock ring groove
15. Insert the lock ring (C) in the groove. Make sure the lock ring seated properly
16. Charge the reservoir with Nitrogen Gas or air at a pressure between 116 psi to 290psi
17. Assemble the pad bearing washer (see picture)
18. Insert the vulcolan pad
19. Screw the upper eye with locktite and tighten carefully.



Shock absorbers - additional program

With the MC-Machines of today and with the roughness of the Moto Cross races of today it is not possible to do with one damper adjustment and with one pair of springs for shocks. You have to adjust your machine according to track. For this reason we have in our program additionally to the normal adjustment two more damping adjustments and two more spring pairs for shocks in our program.

Damper adjustment

Term	type of track	
5G	Enduro	additional program
2H	Grand Prix	standard-type
8E	sand	additional program

Springs

Term	characteristic	length	wire diameter	winding	colour
a=short	hard	70 mm	7,6 mm	4 5/8	black
A=long	hard	230 mm	8,5 mm	10 1/4	black
b=short	medium	70 mm	7,5 mm	5	red
B=long	medium	228 mm	8,7 mm	11 1/2	red
c=short	soft	70 mm	7,5 mm	5 1/2	golden
C=long	soft	228 mm	8,5 mm	11 1/2	golden

The springs b=short and B=long are used in series.

Advice for spring adjustment

Rear wheel suspension reacts badly	well	badly
1. Less preload	don't change anything	now 2.
2. Short spring softer	don't change anything	now 3.
3. Short spring softer	don't change anything	other dampening adjustment
Rear suspension is too weak	well	badly
1. More preload	don't change anything	now 2.
2. Long spring harder	don't change anything	now 3.
3. Short spring harder	don't change anything	other dampening adjustment



3.7 Exhaust system and silencer

Exhaust system and silencer are built according the newest noise-rules, fixed of FIM for Moto Cross.

The exhaust system must be renewed in case its diameter has been damaged very much by crashed and falling stones. If there should appear depositions in the exhaust system, they can be burnt out with an oxygen-flame. Removal of exhaust system(see chapt. 5.1.3).

The silencer should be refilled with steel wool after 5-7 races (MC 490 about 3 races), because otherwise the noise exceeds the allowed tolerance-level and power is lost within lower speed-range.

Refilling of silencer

1. Loosen circlip

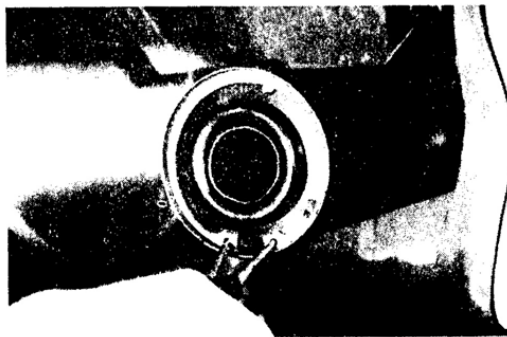

2. Take off end piece



3. Refill silencer with steel wool

4. Put on end piece

5. Install circlip



3.8 Handlebars, fittings and cables

Handlebars are connected with upper cross head by 2 clamps for handlebar.

The fittings

The fittings are made by Magura. They should be cleaned after every race and newly greased.

The twist grip

The twist grip also must be checked carefully. You have to pay attention that throttle cable can be used without jerks and return by itself after being loosened into its former position. It is recommended to disassemble, to wash and to grease twist grip every 3-4 races.

Inspecting the fittings

1. Check all screws for proper tightness
2. Control whether clutch play of 2-3 mm is in order
3. Check whether clamp nuts for handlebars are tightened
4. Check position of handle bars
5. Check whether rubber grip as well as rubber for twist grip is still wrongly fixed
6. Check short circuit button for its function
7. Throttle cable must have 2-3mm play
8. Check right adjustment of front wheel brake.

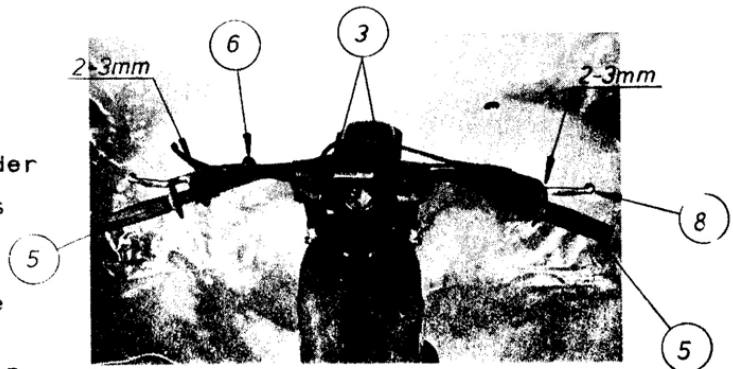

The cables

The cables must be checked regularly for their free-moving. Damaged cables have to be replaced for reasons of security. Pay special attention to wear at throttle cable and hand brake cable.

Throttle cable - adjusting play

1. Take off the rubber socket
2. Loosen check nut and adjust play at the nut (2-3mm at twist grip)
3. Tighten hexagon nut and put on rubber bush.

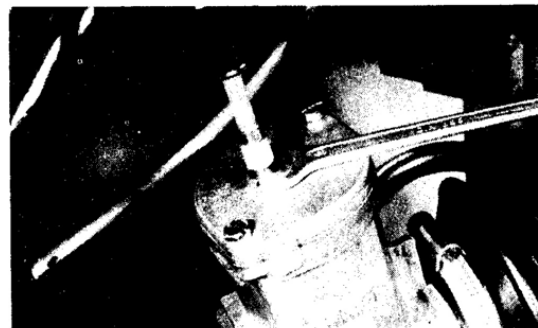

Gas throttle must be layed according to by-standing picture.

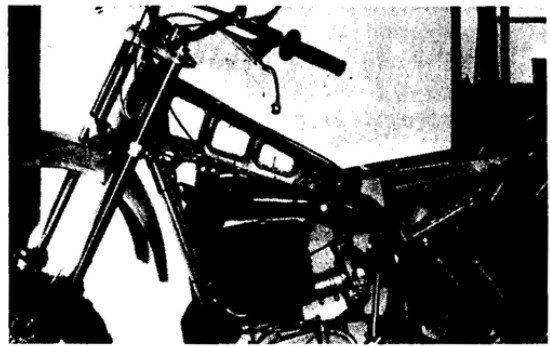

Brake cable

Adjusting of brakes (see chapt. 3.5.1).

The brake cable must be layed according to by-standing picture.

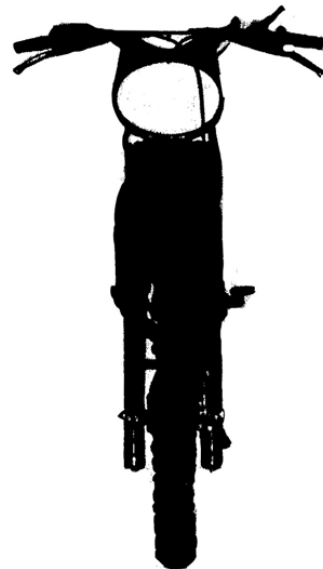

Clutch cable

The clutch cable must be adjusted by means of set screw in such a way that there should be 2-3mm play at the clutch lever.

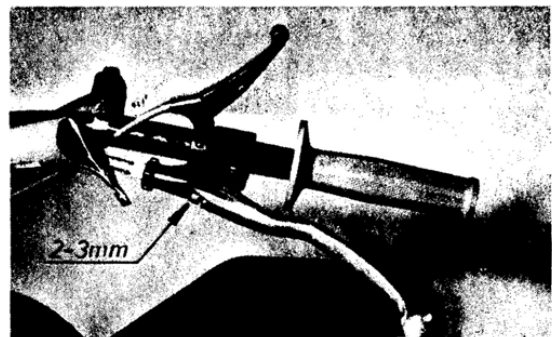

The clutch cable must be
laid according to by-
standing picture.

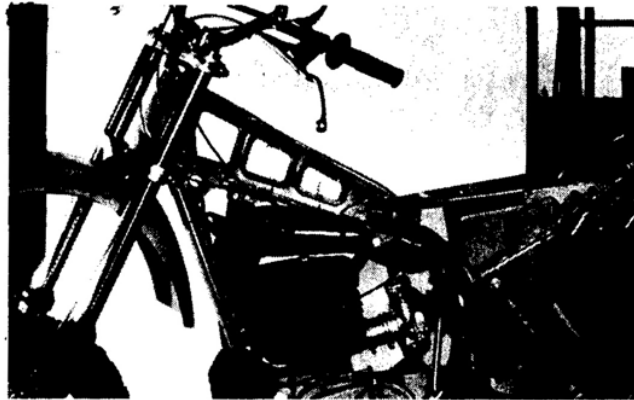

Lubricating the cables

The cables should be lubricated before every race.
We recommend BEL RAY MC 22 (6 in 1).

You should fill an old sprayer with lubricant to spray
that lubricant into the cables.



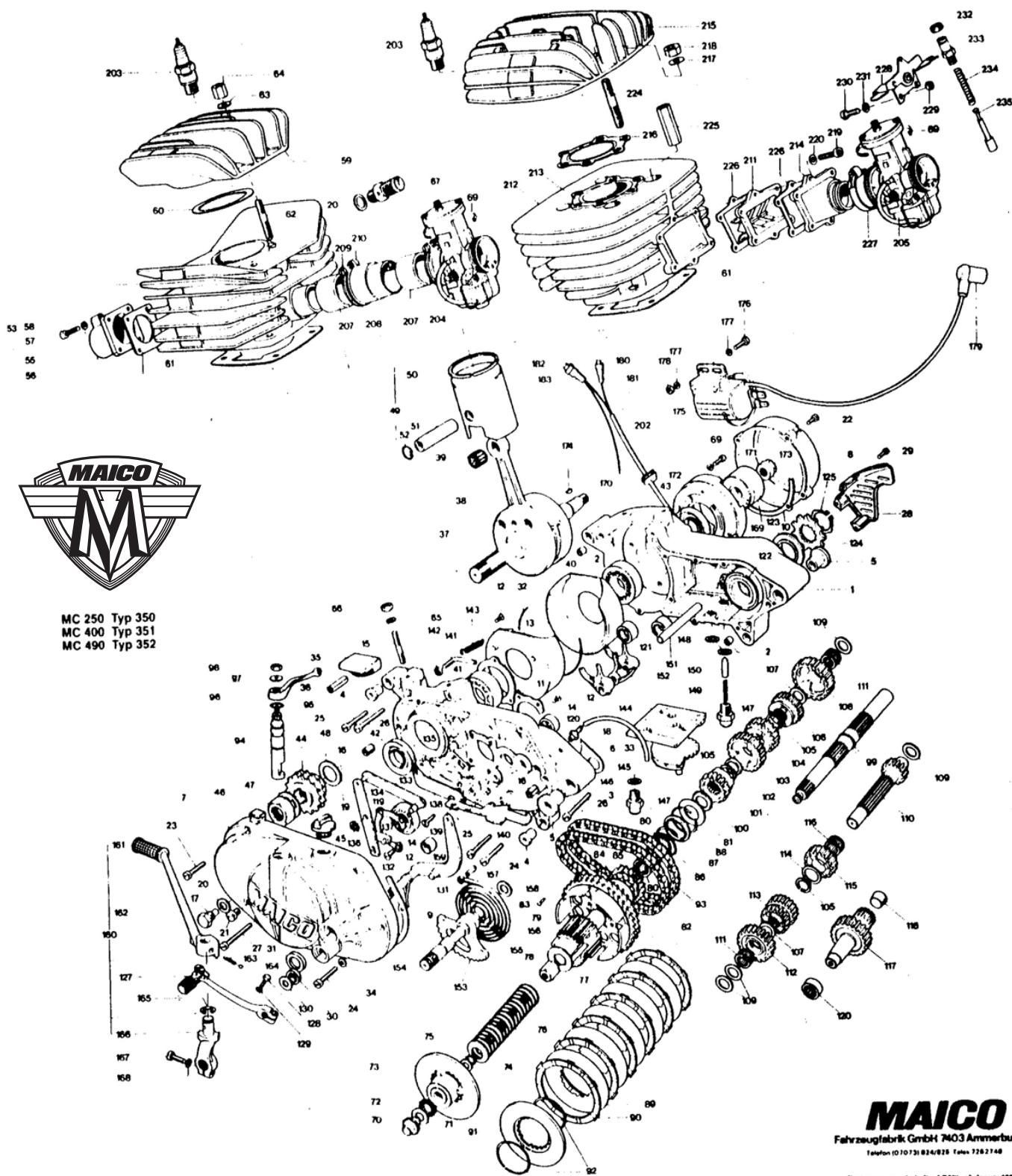

MC 250 Typ 350
 MC 400 Typ 351
 MC 490 Typ 352

MAICO
 Fahrzeugfabrik GmbH 7403 Ammerbuch 2
 Telefon (0714) 824/829 Fax 7282748
 Änderungen vorbehalten! Gültig ab Januar 1981

4.2 General description of engine

The air-cooled, two-stroke, high-performance-engine is equipped with dog-shifting, 5-speed gear box.

The cylinder is light alloy with shrunken cast iron cylinder sleeve. The cylinder base gasket is 0,5 mm thick (Abil-gasket).

The cylinder head gasket is 0,6 mm co-sheet metal.

The MAICO-piston is made with a special forged piston and coated by a hugh volume of silicone mixture. The piston is provided with only 1 L-ring (see technical data 2.2.2).

The crankshaft halves are forged and received heat treatment after machining. The right half of the crankshaft (magnet-side) has a conical profile, the left half (primary drive side) has a splined shaft profile. The connecting rod is forged and has tempered needle bearing seatings.

The allowed radial play tolerance are for

-big end bearing 0.03 mm - 0.04 mm

-piston pin bearing 0.002 mm - 0.004 mm.

Play should be checked before inserting crankshaft.

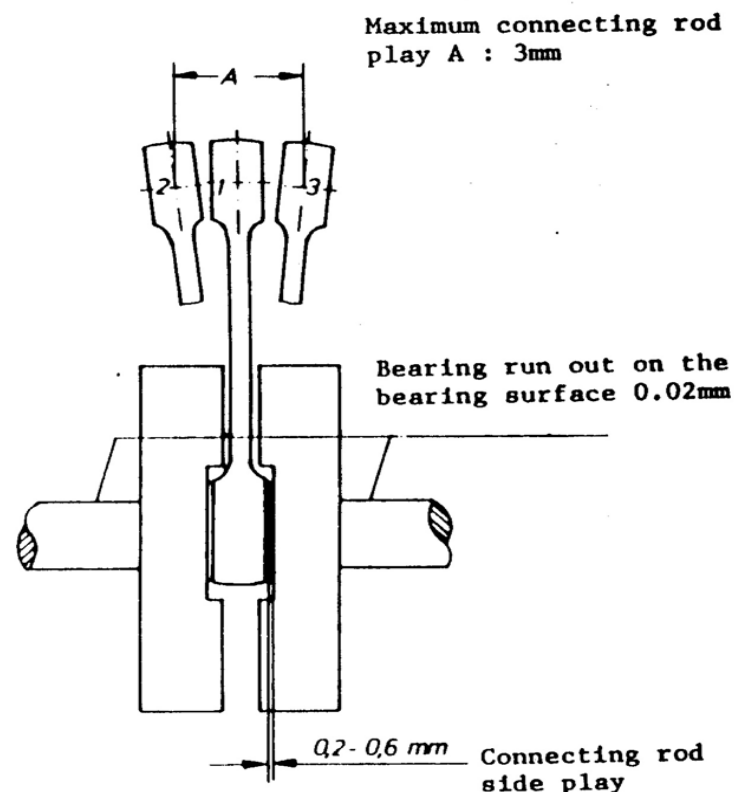

Transmission and clutch are greased by one oil filling.
 The clutch is an oil bath clutch with 6 sintel metal lined clutch discs and 6 steel inner discs.
 The ignition is a motoplat pointless ignition.

5.0 Engine removal from the frame

5.1.1 Repairs requiring engine removal

- servicing the clutch
- servicing the crankshaft
- changing the crankshaft bearing
- changing the shaft bearing

If there should be any other services necessary with the engine, it is recommended to remove the engine.

5.1.2 General remarks

Before removal clean the engine properly.

5.1.3 Engine removal

1. Close the pet cock
 2. Loosen the nuts at the seat and remove the seat
 3. Loosen the strap at the tank
-
4. Pull off the hose at the carburetor and take off the tank
 5. Loosen the nuts for the side panels and take off side panels
 6. Loosen screw for silencer
 7. Open the chain lock and take off the chain
 8. Hang out the brake rod.

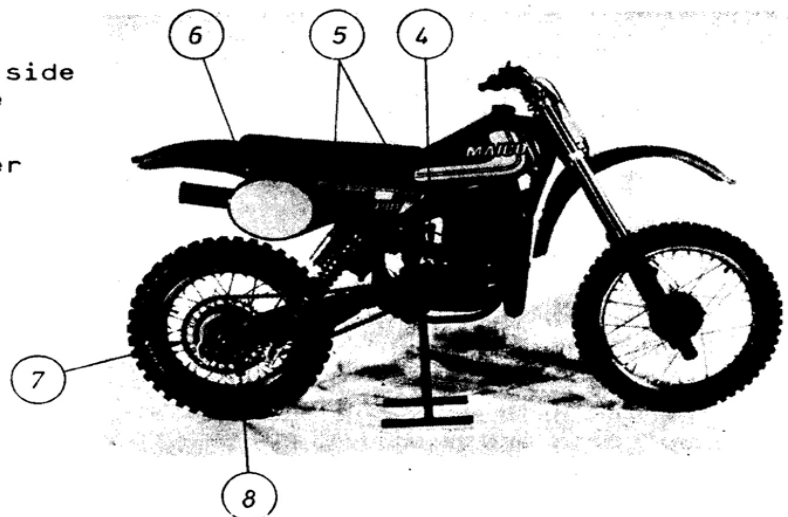
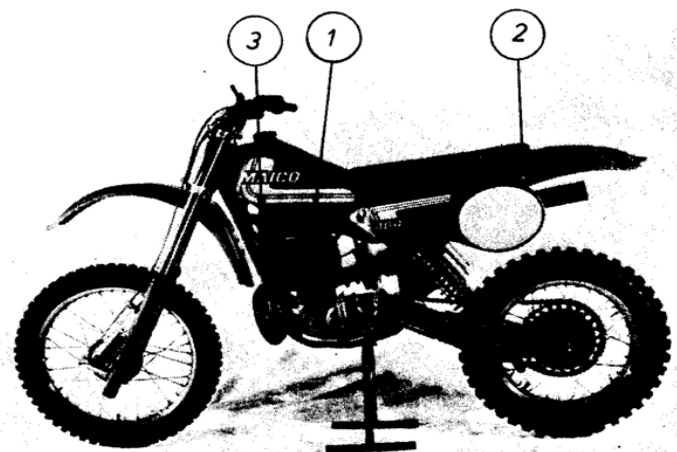

9. Open clamp at silencer



10. Loosen nuts for exhaust system

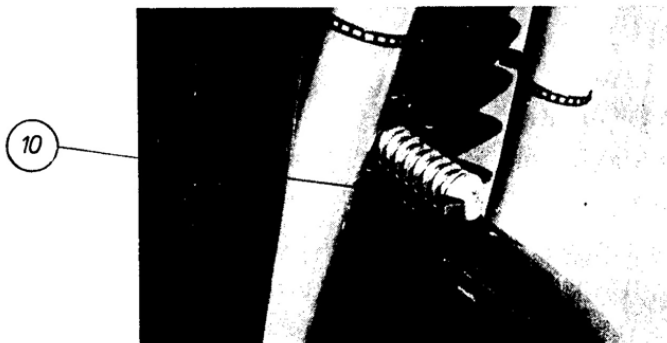
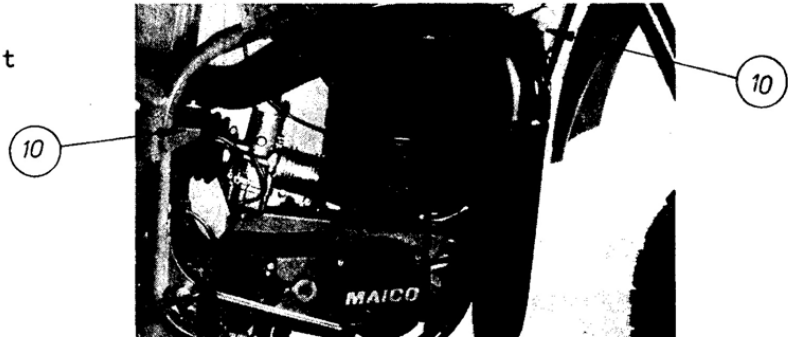

11. Pull off high tension lead. Pull off cable plug

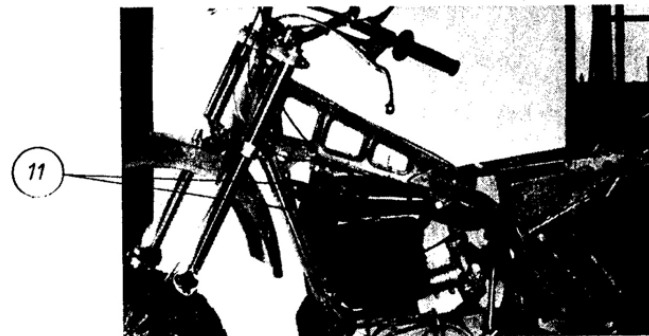

12. Hang out clutch cable

13. Loosen front motormount bolts and pull them out

14. Loosen axle nuts and pull out axle and mounting bolts to secure swing arm at the same time

15. Loosen clamp at carburetor and pull carburetor off cylinder.

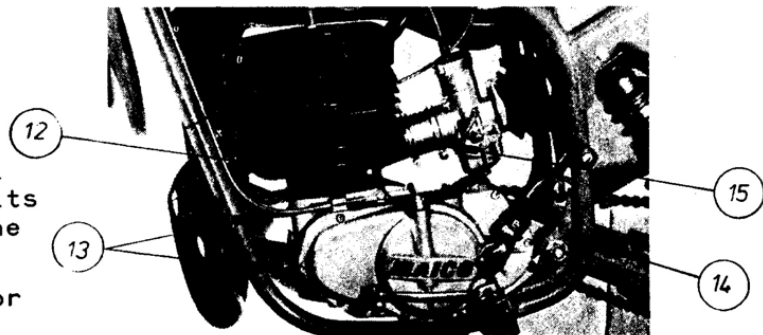

16. Loosen the nuts of cylinder head stay (at frame and cylinder)
17. Now the engine can be taken out to the left.

5.1.4 Engine

Left side of engine (clutch, kickstarter and shifting lever)

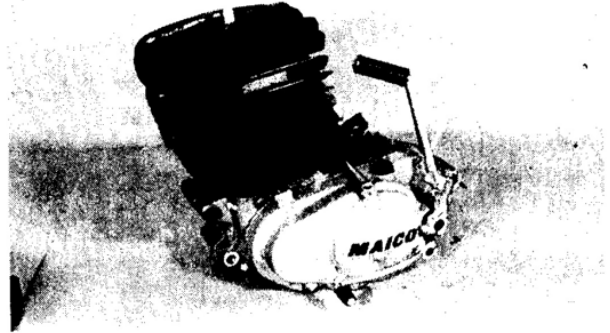

Right side of engine (generator and sprocket)



5.1.5 Disassembling the engine

1. Open nut for cylinder head
2. Take off cylinder head



3. Open nuts for cylinder base
4. Remove cylinder
5. Take off cylinder base gasket



6. Put a clean cloth on the crankcase
7. Remove safety bolts with a pair of tongs



8. Push out piston bolt with a gudgeon pin and take off piston with bolt and needle bearing.
ATTENTION: When pushing out piston bolt it is necessary to hold the piston against it, otherwise the connecting rod could be bent.

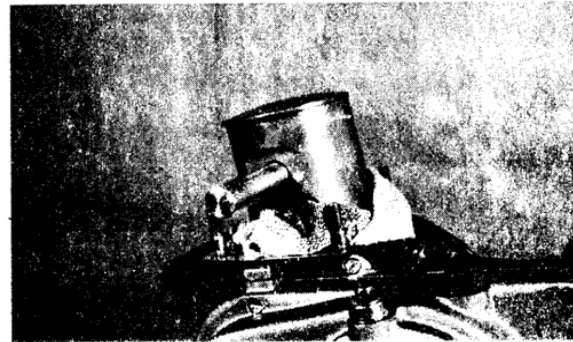

Check cylinder, piston and needle bearing for wear.

9. Open and screw out nut at kick-starter
10. Open screws of left crankcase cover, remove cover and drain off the oil
11. Remove cover gasket

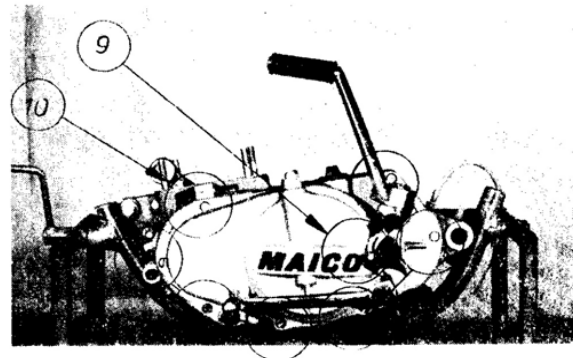

12. Set on and straighten puller for clutch

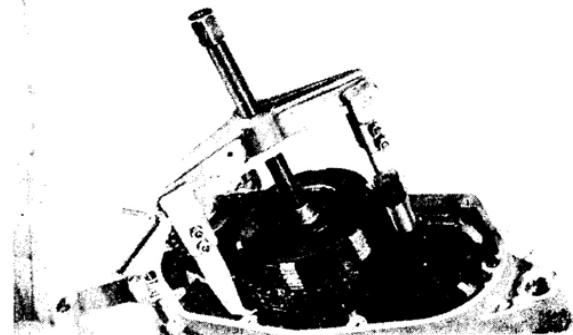

13. Take out spring ring, slowly loosen the puller and remove it, pull out clutch with guide for clutch disc

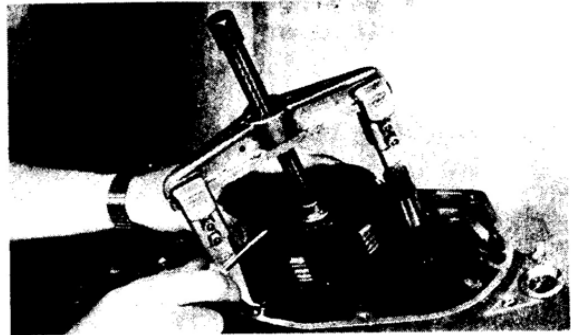

14. Stem out securing tin (with inner hexagon) for clutch with 2 screwdrivers

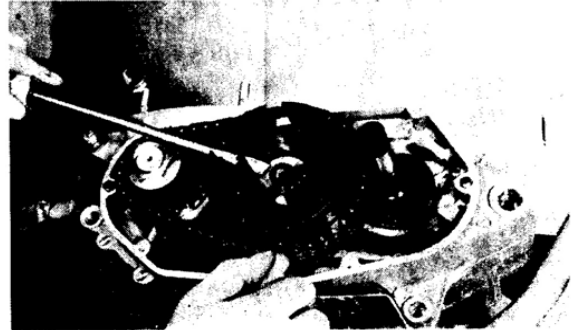

15. Insert lock disc and open hexagon screw, then pull off clutch body

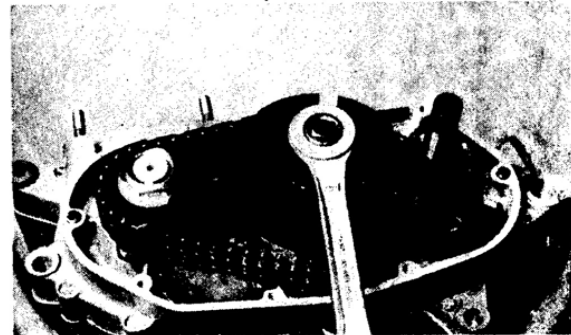

16. Take out clutch housing and the 2 chains

17. Take off spacer washer

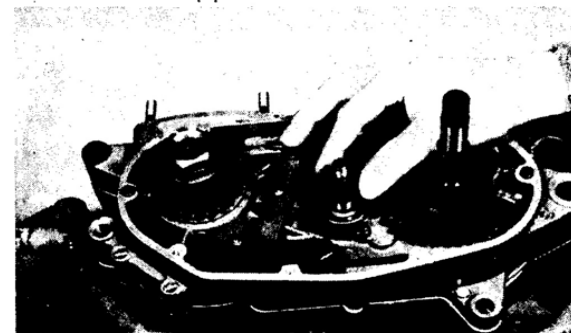

18. Open securing tin at primary sprocket
19. Set on back-up tool for sprocket onto the crankshaft and open the nut
20. Take off nut, securing tin and primary sprocket.

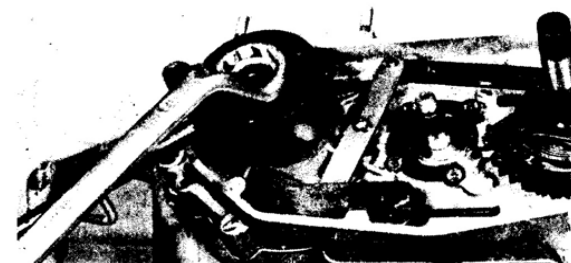

21. Remove tin only when it is damaged at hooked ratched, pullrod or pullrod pivot arm

21

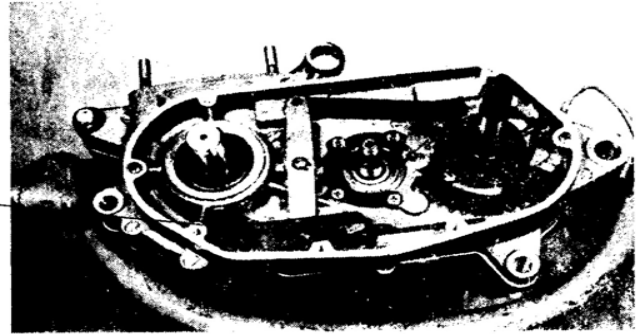

22. Insert kickstarter and pull out carefully shifting segment with kickstarter for 1 cm, after that turn left and loosen spring, now pull out kickstarter segment

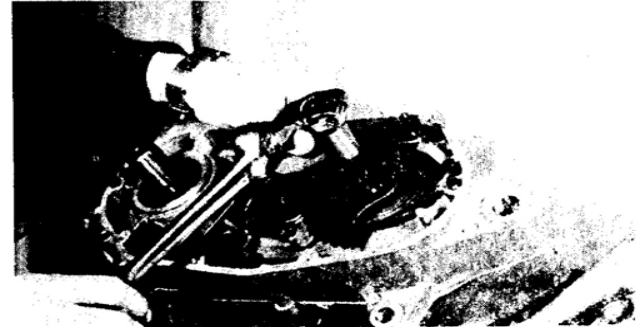

23. Loosen screws and take off left housing part and gasket

23

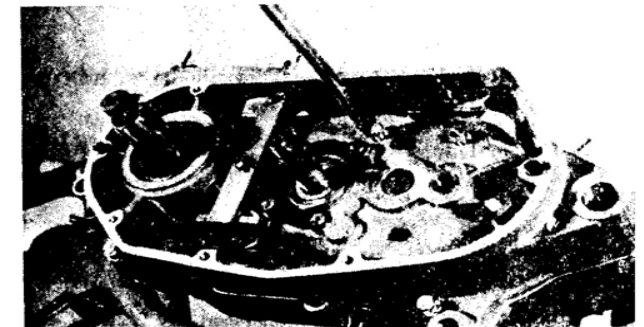
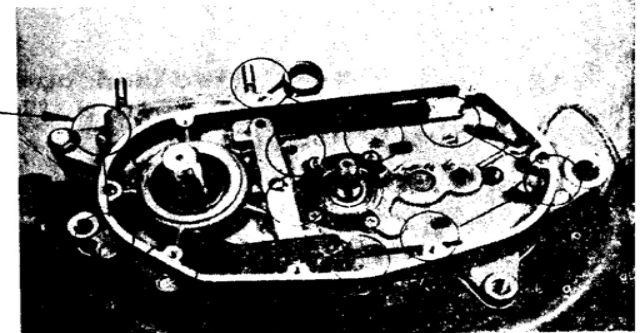

24. Pull out gear selection fork spindle

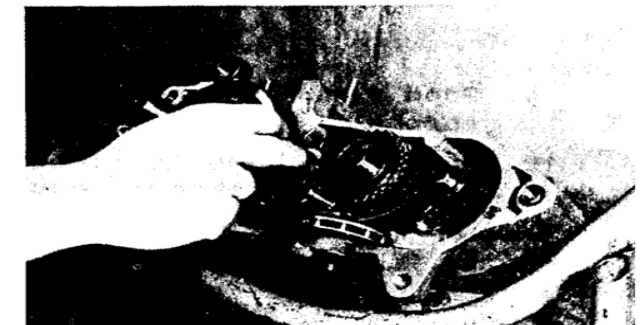

- 26 a.) Pull off 1st gear layshaft and mainshaft with gear selection fork
- b.) Pull out mainshaft with 2nd gear and gear selection fork
- c.) Pull out layshaft cpl. with twin bloc and gear selection fork
- d.) Take out 5th gear mainshaft

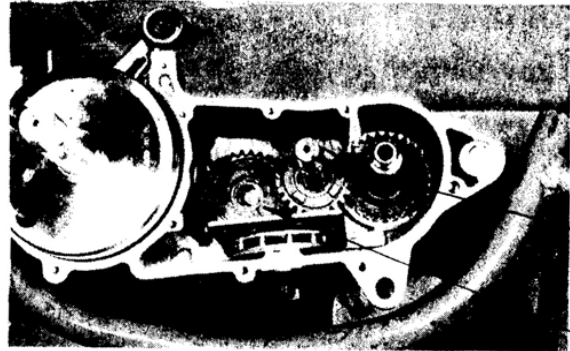

26c

26d

Check needle bearing

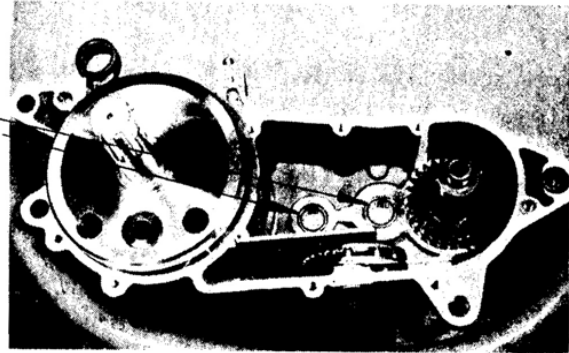

- 27. Loosen guide screw of shifting plate, raise and take out shifting plate with shifting segment



- 28. Screw off cover of generator
- 29. Loosen and take off nuts at stator

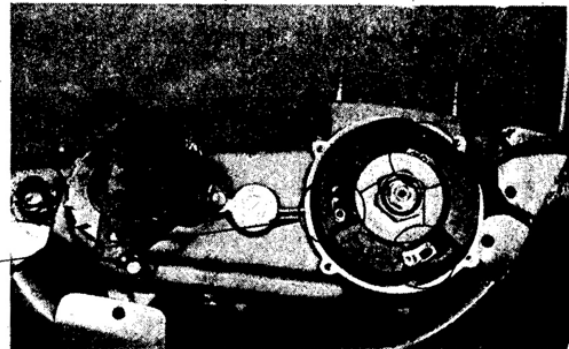

29



30. Loosen nut at rotor
CAUTION: left hand thread
31. Set on puller for rotor
and pull of rotor
32. Take crankshaft out of right
crankcase part

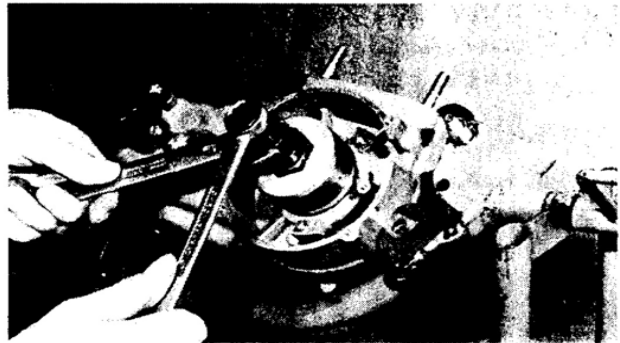

- E n i n e i s d i s a s s e m b l e d -

5.1.6 Inspecting and repairing

1. Before every kind of inspection and repairing all parts have to be cleaned properly. Clean the parts with engine cleaner or petrol and dry them with a fibreless cloth.
2. Check all parts, especially the cast parts for cracks. Damaged parts are to be replaced or to be repaired by a specialist.
3. New measures, limits of wear and overseizes are included in the technical datas in Chapter 2.2.2.

5.1.7 Inspecting the disassembled parts

1. Check the gear wheels (check teeth for pitting, gear shifting forks for extreme wear)
2. Check gear shift fork for pressure points and wear
3. Check whether gear selection fork spindle is bent
4. Check shifting plate and shifting segment
5. Check needle bearing on mainshaft and layshaft for pitting
6. Crankcase left and right
 - a. check needle bearing of mainshaft and layshaft
 - b. check sealing rings
 - c. check needle bearing of crankcase for light play.

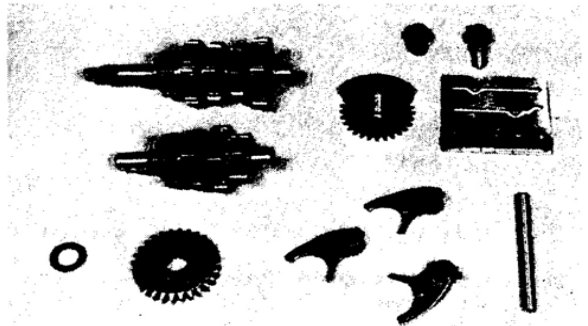

7. Check connecting rod for radial and axial play (see chapt. 4,2). When connecting rod at UT-position is in contact with both fly wheel halves the connecting rod bearing has to be exchanged.
8. Check pistons and cylinders for wear. Check fixing pin of piston ring for fixed position. Piston ring mustn't have much play in pressed position.

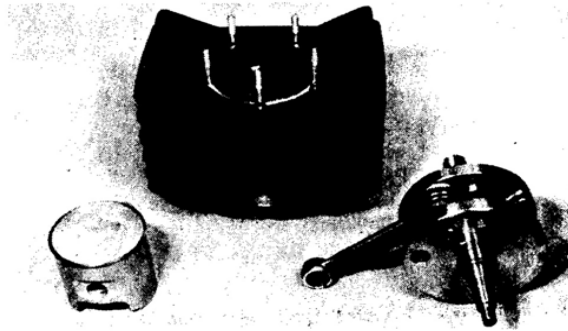

The reed valve engine

The reed valve engine must be checked from time to time whether parts of lips for reed valves are broken

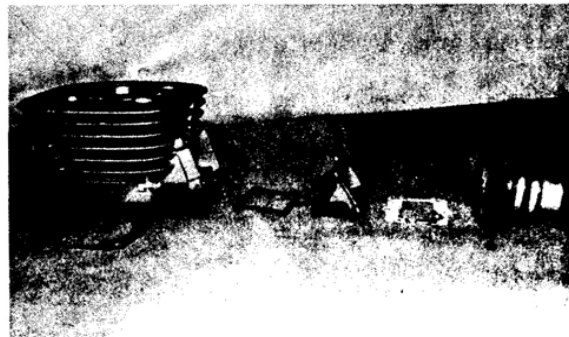

9. Check gear change crank with gear change crank gauge. The checking pin of gauge must be put easily through gauge and bore of gear change crank. If the bores do not cover each other, the gear change crank has to be adjusted.

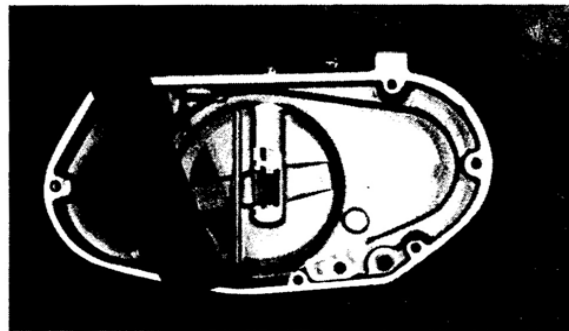

Adjusting of gear change crank

Bend the ends of gear change crank springs to the left or right until the wanted position is reached. The spring ends have to be thus set that the gear change crank has no or very little play.



10. Check primary chains for length adjustment
11. Check inner discs with gauge for evenness
12. Check cams of outer discs whether they are cut in. When they are cut in badly change outer discs
13. Check needle bearing and needle bearing position at clutch body
14. Check kickstarter segment for wear.

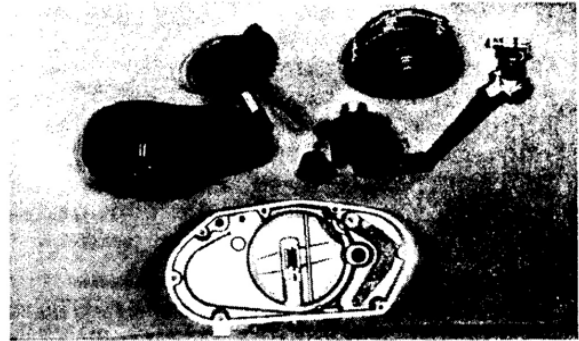

5.1,8 General remarks

Assembling the engine

1. When assembling the engine you should pay attention to cleanliness. All parts including the bearings have to be greased or oiled.
2. All screws and nuts have to be tightened according to torques in chapt. 2.2.5
3. All gaskets and security tins have to be exchanged. When inserting new sealing rings you have to be careful. It is advisable to grease them before inserting with graphit grease at the connecting surface to avoid wear.
4. All the grease rests at connecting surfaces have to be removed carefully.
5. Before assembling be sure to have all the necessary gaskets and locks.
6. Don't forget to clean the tools before dirt is assembling which could easily get into the engine.



5.1.9 Assembling the engine

1. Insert crankshaft into right crankcase
2. Mount the rotor (don't forget the key). Tighten fixing nut, (left hand thread)
3. Insert shifting segment and shifting plate, engage mark at lower side of shifting segment (at 5th teeth) into shifting plate when in idle position (small recess).
4. Insert shifting plate with shifting segment into case
5. Mount guide nut on crankshaft of shifting segment
6. Slightly tighten pawl pin with guide nut
7. Put spacer washer (5th gear) onto the needle bearing outside.

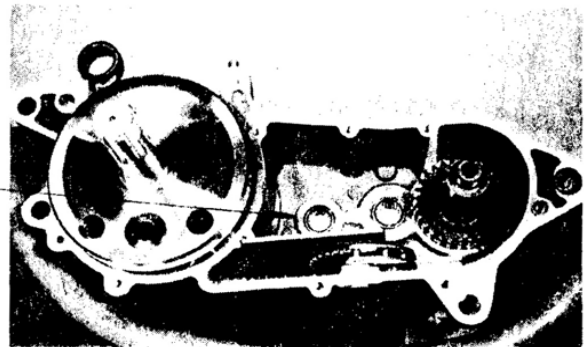
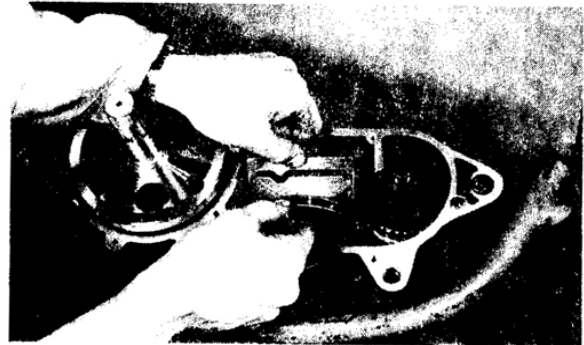
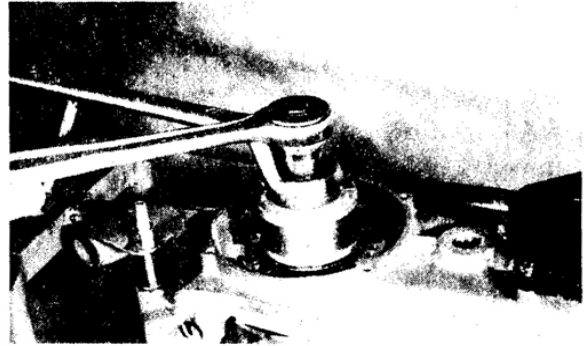

- shift to 5th gear, insert needle bearing and put in spacer washer (small)
- put spacer washer onto layshaft and insert layshaft
- insert 2nd gear on mainshaft with shift fork
- insert twin bloc on layshaft with shift fork
- insert main shaft
- stick 1st gear with shift fork on mainshaft
- insert gear selection fork spindle
- spacer washer (small) on layshaft

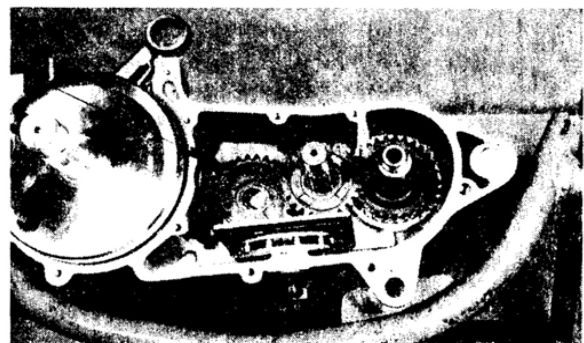

- stick needle bearing for 1st gear on layshaft , stick 1st gear on layshaft, stick 2 spacer washers on layshaft (possible sizes 0.8 mm and 1.0 mm)
- lay spacer washer on drive shaft
- lay washer for mainshaft on 1st gear

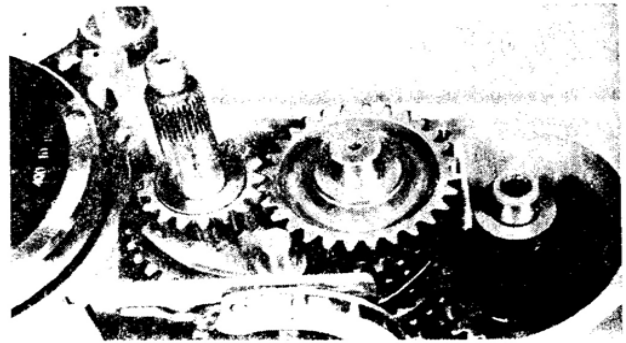

- tighten guide nut for pawl pin



Functional control

Turn mainshaft and shift at the same time all the gears with a screw-turner at shifting segment

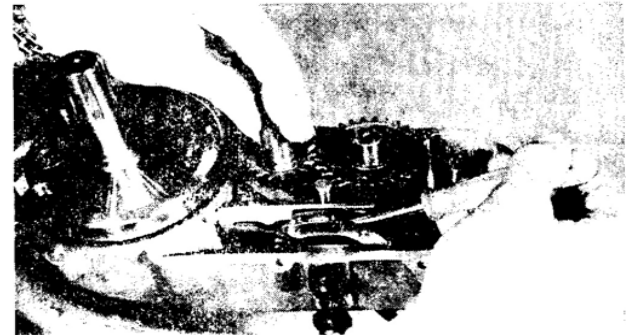

8. grease crankcase gasket on both sides and lay it on right crankcase
9. Put on left crankcase
10. Tighten screws (don't forget the screw under pullrod pivot arm).



11. Hang kickstarter spring into crankcase. Stick kickstarter onto kickstarter segment and tension spring one turn further. Now press in kickstarter segment thoroughly and take off kickstarter

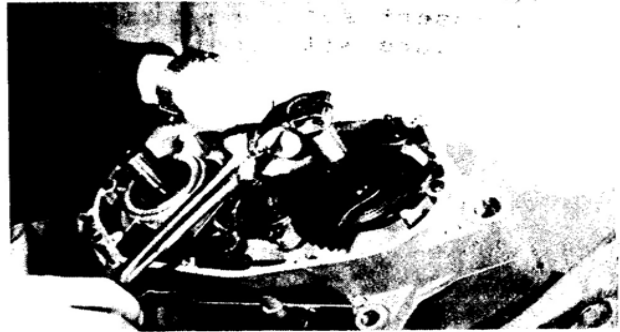

12. Put sprocket with securing disc onto crankshaft. Stop sprocket with special tools and tighten nut with securing tin.

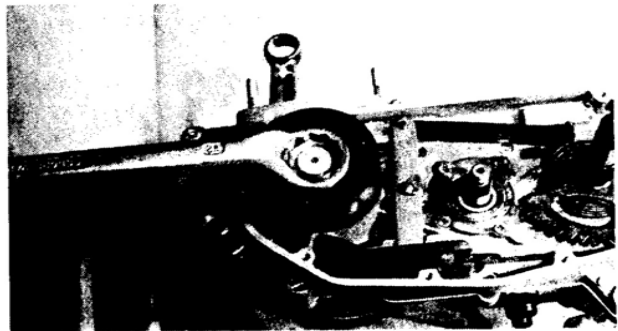

13. Put spacer washer onto main disc

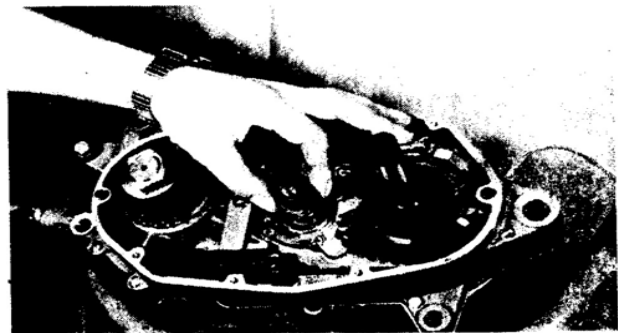

14. Insert clutch case with primary chains, insert needle bearing and clutch body. Set nut onto mainshaft and hold clutch body with the special tool and tighten nut

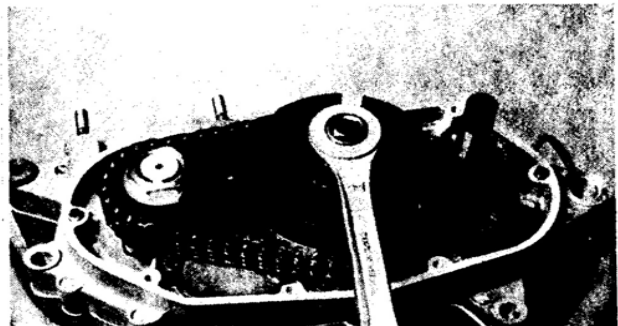

15. Insert securing tin and secure with special tool

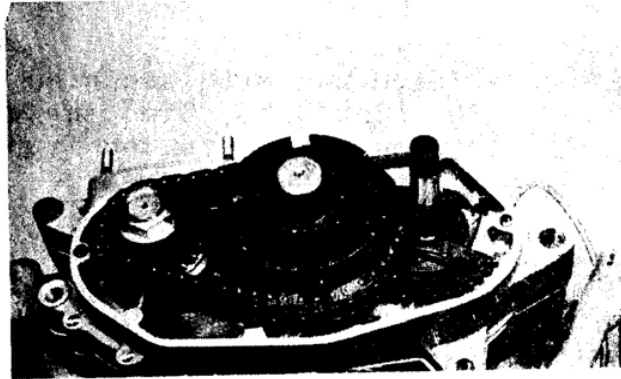
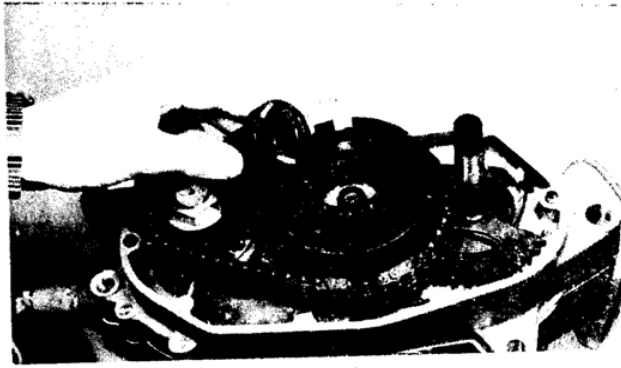

16. Insert clutch springs with those pairs into clutch body

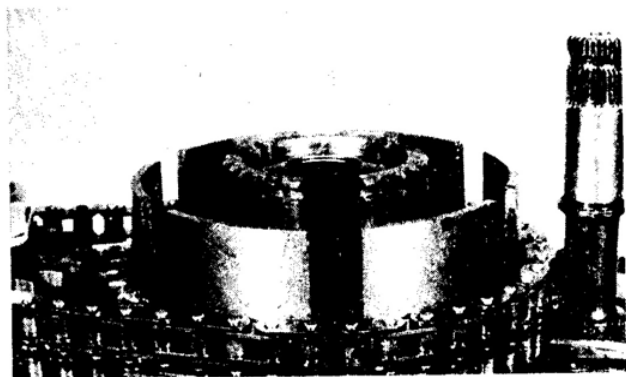
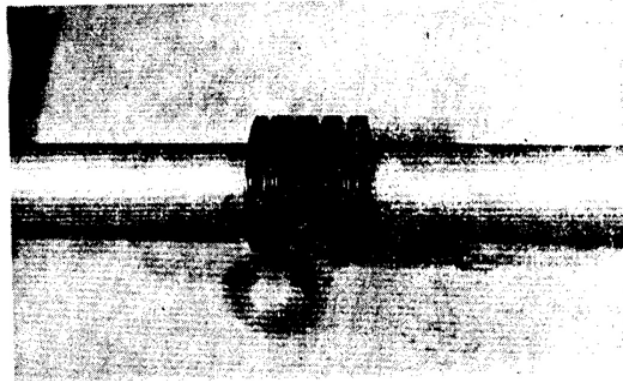

17. Stick on guide for clutch disc and insert discs in correct order (at first outer disc)
CAUTION: Put together 2 inner discs in the middle



18. Set on clutch extractor and pretension plate springs

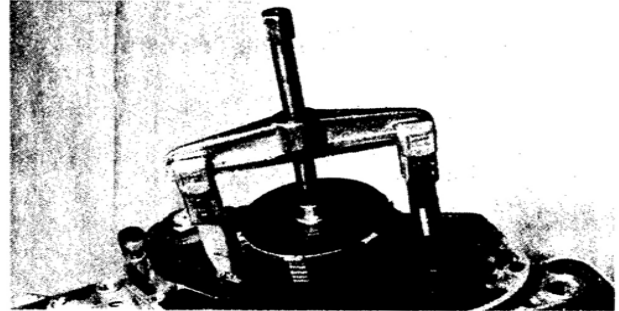

- 18.a Mount securing ring with a screwdriver



19. Now the transmission oil can be filled in (600 ccm engine oil SAE 20W - 50 (HD) or BEL RAY MC4)

20. Before closing the engine the gear crank should be checked by a gauge for gear crank (s.chapt. 5.1.7)

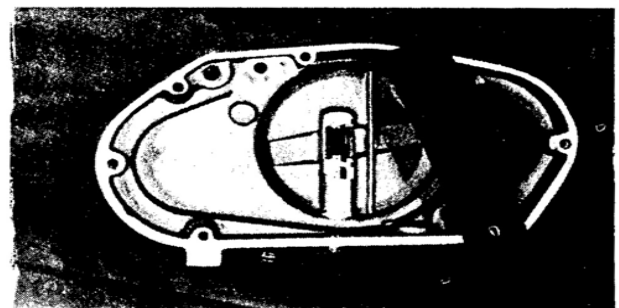

21. Grease crankcase cover gasket on both sides and lay it onto left crankcase.



22. Attach crankcase cover and pay attention that gear crank is engaged in pullrod, tighten 2 nuts and check whether gear crank is engaged in pullrod
23. Tighten all screws at crankcase cover
24. Put on cylinder base gasket
25. Mount piston (sign at piston must show into exhaust direction). Use new securing rings



26. Set on cylinder and slightly tighten cylinder base nuts.
CAUTION: take special care of the MC 250 reed valve engine. Piston ring moves easily into inlet and can brake



27. Measure with gauge the distance between upper end of piston ring and upper part of cylinder liner. Distance should be 0.4 to 0.6 mm.

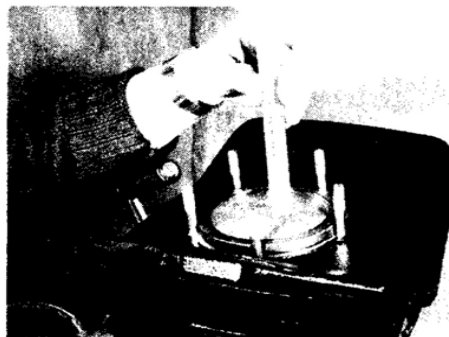

If this measure cannot be reached use thicker or thinner cylinder base gasket.

If this measure is correct the cylinder base nuts can be tightened. Attach cylinder head and tighten nuts (don't forget screws for cylinder head stay.).

Torques see chapt. 2.2.5.

28. Attach stator and tighten slightly

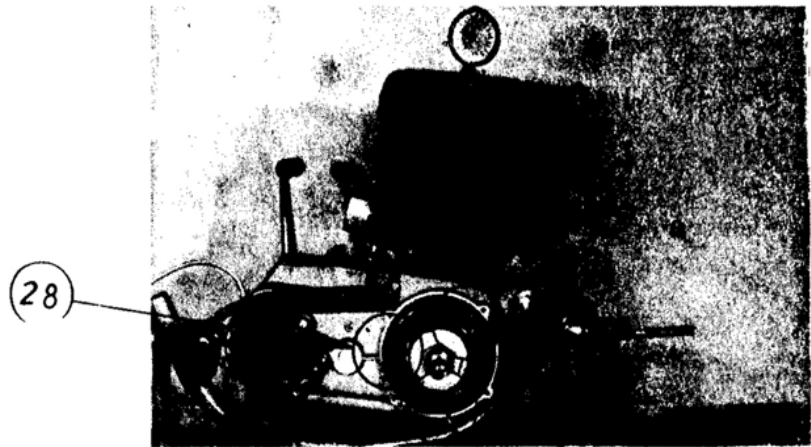

29. Screw gauge by means of gauge holder into spark plug hole. Adjust zero-position of gauge on upper death point.

The marks at rotor and stator have to overlap according to preignition.

Preignition: 250 ccm = 1,8 mm \pm 0.1 before upper death point
 400 ccm = 2,1 mm \pm 0.1 before upper death point
 490 ccm = 2,1 mm \pm 0.1 before upper death point

Tighten screws when exactly overlapping.

Correct preignition

Marks at rotor and stator have to overlap when preignition is adjusted properly

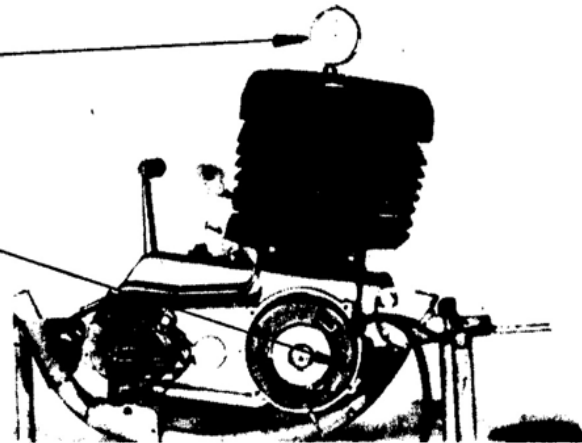

30. Grease gasket for generator cover on both sides, attach it and tighten generator cover.



6.0 Ignition

6.1 Ignition (drawing)

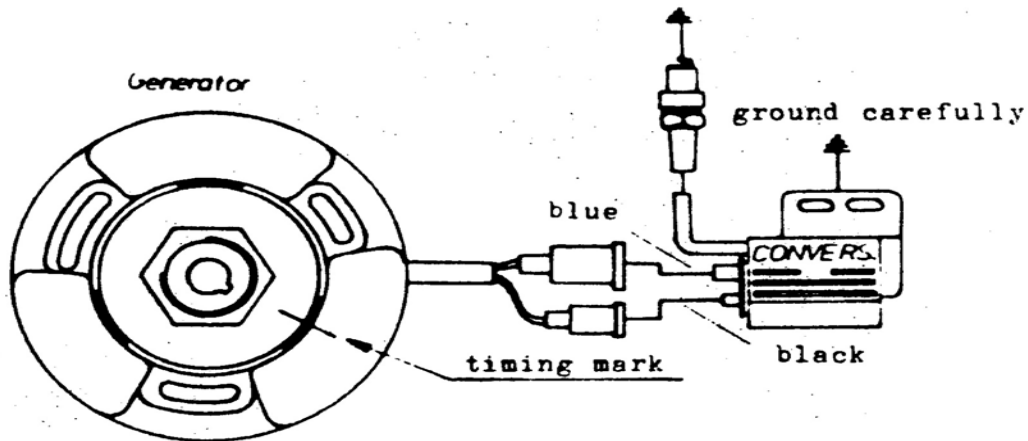

The ignition is a motoplatt pointless ignition. Ignition coil must always be grounded to the frame, solid mounting, without silent bloc or ground wires. Never kick or turn engine with disconnected spark plug cap. Spark plug must always be grounded. (Ignition will be destroyed if electrical is incomplete.)

6.2 Ignition timing

The proper timing is set by a dial indicator. Screw the dial indicator with aid of the holder for dial indicator into the spark plug thread of the cylinder head. Now the crankshaft is rotated approximately counter clockwise to the specified timing measurement in this position, the mark on the stator plate should match the mark on the magneto rotor.

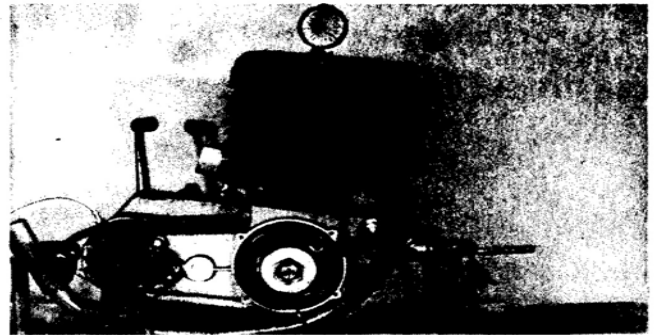

In order to retard the timing, turn the stator in the clockwise direction. To advance the timing turn the stator plate counter clockwise. After tightening the screws check the timing again. Timing marks also can be checked by the timing light pistol.



6.3 Timing marks

Preignition: MC 250 = 1,8 mm \pm 0,1 before upper death point
 MC 400 = 2,1 mm \pm 0,1 before upper death point
 MC 490 = 2,1 mm \pm 0,1 before upper death point

6.4 Spark plugs

For spark plugs we recommend Champion N 2 or 2 G. You can also use spark plugs of other manufacturers with a heat range between 230 - 310. We recommend 310-340 on sand tracks.



7.0 Carburetor

7.1 Explosion chart carburetor

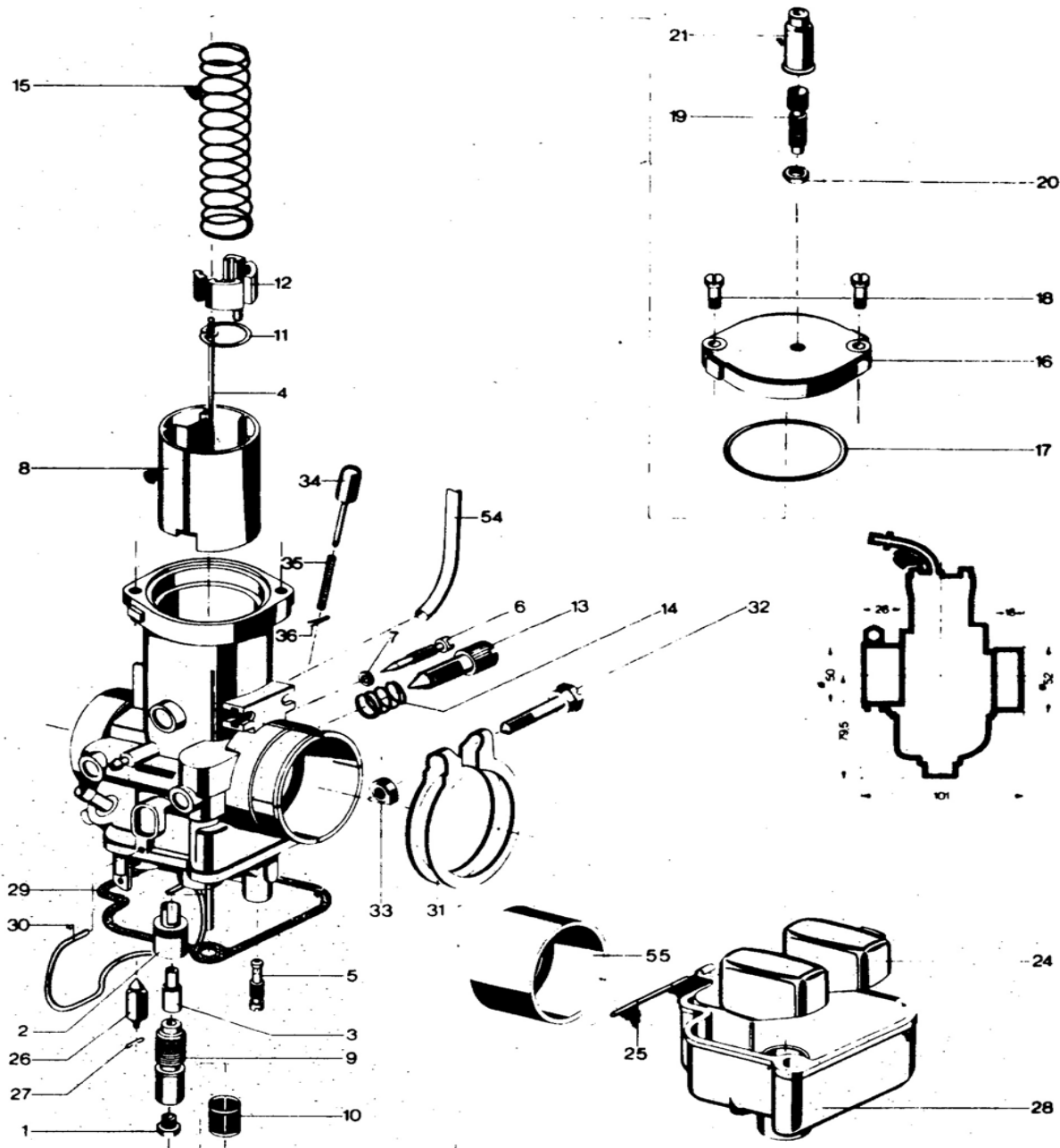

Carburetor MC 250 ϕ 38 mm

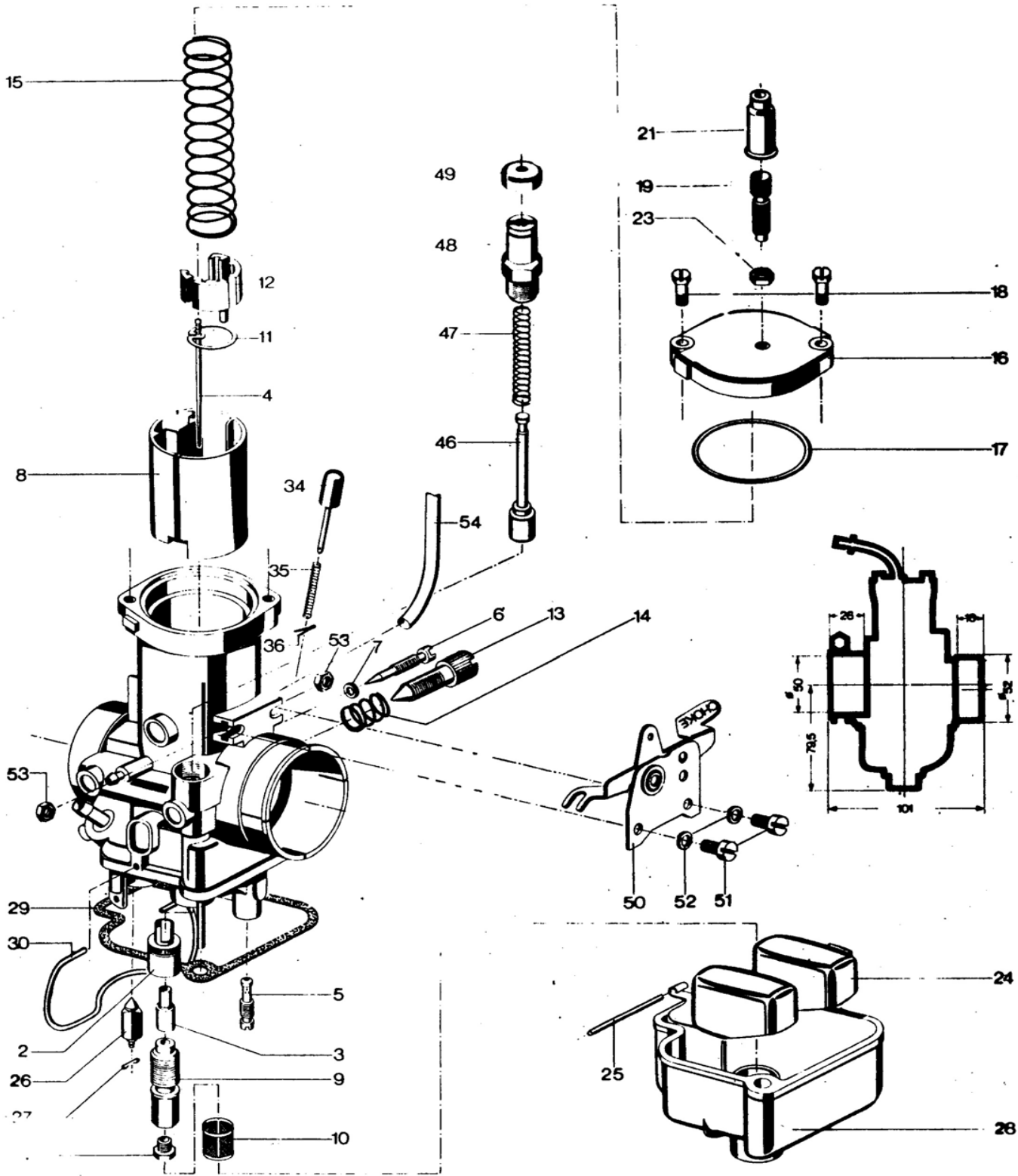

7.2 Technical data

	MC 250	MC 400	MC 490
Types	350	351	352
Carburetor	54-2	54-2	54-2
Diameter	38mm	40mm	40mm
Slide	2103	1201	220
Main jet	195	185-195	185-190
Jet needle	6D2	8G2	6L2
Pilot jet	65	45	45-50
Needle position	2	2	2
Needle jet	2,78-2	2,78-2	2,80-2
Idler air screw	1/2 or 1 turn over		
Carburation	7	3	3

7.3 Timing and jetting

Carburetor functions under following systems

- Pilot (idle) jet: - functions up to 25% throttle slide opening, air regulating screw (small screw) regulates fine adjustment of idle mixture
- Needle jet: - functions from 15% to about 80% of throttle slide opening. Fine adjustment is carried out by altering the needle position
- Main jet: - functions from 50% to 100% of throttle slide opening

Adjustment

All the adjustments should be made only on a warmed up engine. Always change one component only, then test ride again. Never change more components at one time, as in this case you don't know which component had really caused the change.

The basic carburetor jet is valued for 1200 feet above sea level and temperature between 18°C - 25°C (64-77°F) with recommended oil mixture.



Pilot system

Functions when throttle slide is closed. The throttle slide stop screw (idling screw) adjusts idling rpm - approximately 1000rpm. Clean idling is regulated with air regulating screw (small screw). Turning the screw further in gives a richer idling mixture, turning the screw further out gives a leaner idling mixture. When bike is in motion with throttle slide closed and engine idles too fast (lean mixture) use the next larger pilot jet.

Midrange

Functions with throttle slide partially open. Adjustments are made with needle jet and needle position. Adjustment by pilot system for bottom end and by the main jet for top end. If mixture is too rich during acceleration, the needle should be lowered. When engine pings (metallic knocking) during acceleration the needle should be raised. If lowering or raising of needle is not sufficient install smaller or larger needle jet.

Top end

Throttle slide wide open. When engine pings in wide open position (spark plug white), use larger main jet. Installation of larger main jet requires also larger needle jet, so that fuel is not restricted by needle jet. If engine runs too rich, (spark plug dark), use smaller main jet.

7.4 Changing throttle cable

1. Open clamp and pull carburetor out of carburetor manifold
2. Open carburetor cover screws and pull out throttle cable
3. Press together carburetor spring and hang out throttle cable at slide. Hang also out throttle cable at throttle grip and take it out.

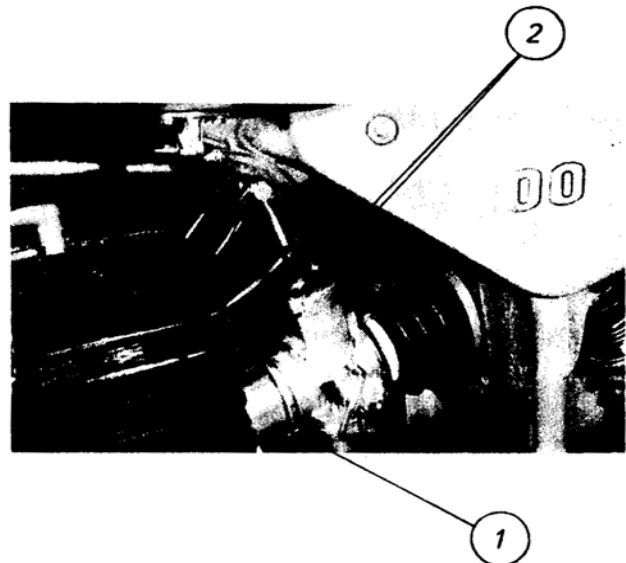

4. Now insert new throttle cable according to picture (chapt.3.8).
5. Push throttle cable through carburetor cover, spring and guide piece. Press spring together and hang throttle cable into throttle slide.
6. Insert throttle slide into carburetor housing and pay attention that the carburetor cover is mounted properly. When mounting is not correctly done you can hear a slight scratching of spring when accelerating.
7. Insert carburetor into carburetor manifold and tighten clamp again.

7.5 Changing jets

7.5.1 Changing main jet

1. Open spring clamp and take off float chamber cover
2. Pull screen leave off jet carrier
3. Screw out main jet with ring or fork key SW 8
4. Screw in wanted jet

Assembling is the reverse order of removal.

7.5.2 Changing needle jet

1. Open spring clamp and take off float chamber cover
2. Pull screen sleeve off jet carrier
3. Screw out jet carrier with ring or fork key SW10
4. Needle jet is falling out by itself
5. Push wanted needle jet with the correct part onto the jet needle (see explosion chart) and screw in jet carrier.

Assembling is the reverse order of removal.

7.5.3 Changing pilot jet

1. Open clamps and turn carburetor sideways
2. Open spring clamps and take off float chamber cover
3. Take screen off pilot jet
4. Screw out pilot jet with small screwdriver
5. Screw in wanted jet

Assembling is the reverse order of removal.

8.0 Chain

To extend the service life of the drive chain use only good quality chains. As the drive chain runs completely unprotected its service life is very short when the maintenance is not correct.

A worn chain also provokes rapid wear of sprockets. In the beginning a new chain is lengthening very much, therefore the tension has to be checked as when the chain has been used before.

8.1 Technical data of the chain

5/8" x 1/4 114 links with lock

8.2 Chain slack

Chain slack should be 5-7 cm. The chain shouldn't be adjusted too taut. It mustn't be possible to press the chain higher with the finger than it is shown in the picture. (tension chain, see chapt.3,5 assembly of rear wheel).

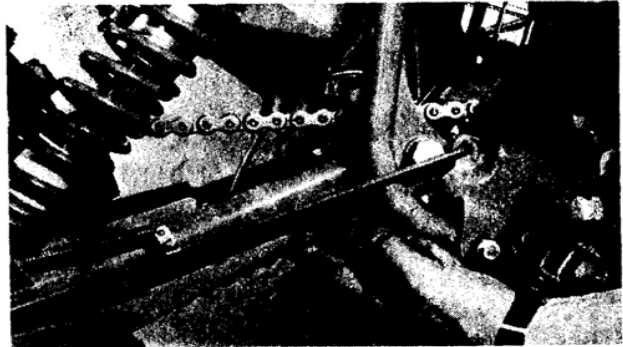

8.3 Chain maintenance

Chain should be treated before every run with an oil or chain spray. We recommend BEL RAY MC 2.

After long use it is advisable to clean the drive chain in solvent and to boil it in fat containing MOS_2 .

8.4 Sprockets

Check the rear and front sprocket for damage. Replace any chain with damages.

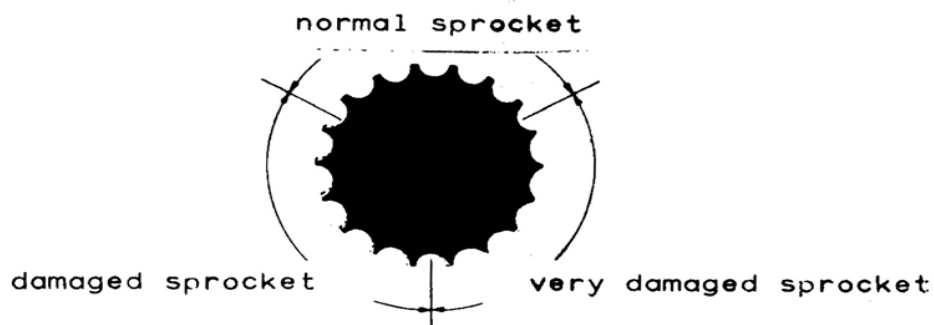

CAUTION: Never use a new drive chain on badly worn or damaged sprockets. Both chain and sprockets must be in good condition, or the new replacement chain or sprocket will wear rapidly.

9.0 Maintenance

9.1 Maintenance and preparation for repairs

1. Clean the machine properly before repairing to avoid dirt getting into the machine parts.
2. Several screws of the engine are tightened very much, therefore a piercer should be used for opening.
3. Tighten the screws and nuts according to torques (s.technical data).
4. Don't use force when removing parts. If you can't loosen a part check whether all the appropriate parts and screws have been opened.
5. When assembling always use new gaskets and o-rings.
6. Before assembling oil and grease the parts where it is demanded.
7. Use special tools when demanded.
8. Always use MAICO original spare parts as only they guarantee a troublefree function.

9.2 The tools

Use when demanded the special tools developed by us. They ensure you an easier and faster working.



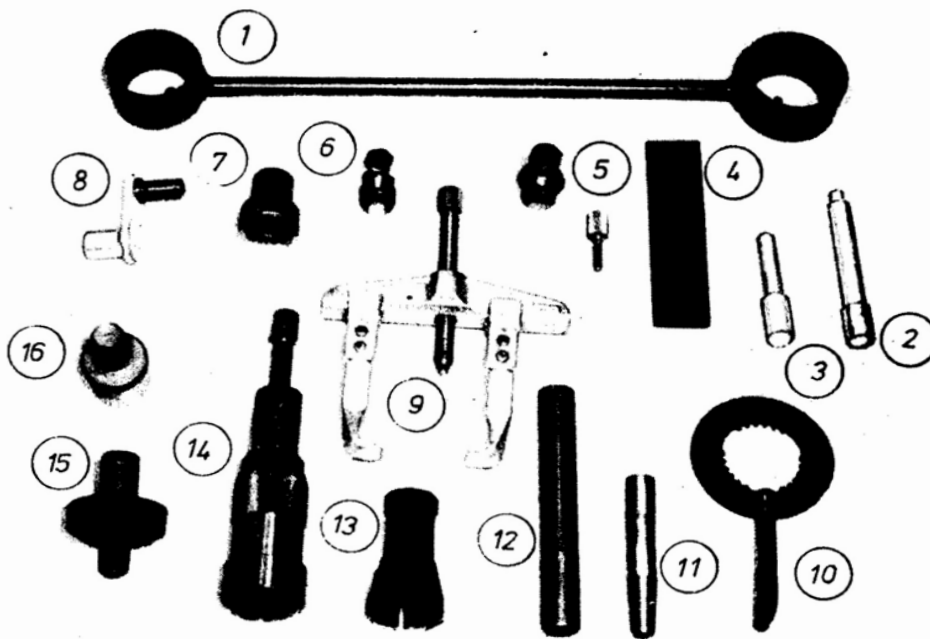

1. Locking tool for crankshaft sprocket
2. Gudgeon pin drift
3. Pin for rear swing arm
4. Control gauge for gear change crank
5. Extractor motoplat
6. Extractor Bosch
7. Driving rod for lock washer on clutch
8. Dial gauge for ignition timing
9. Clutch extractor
10. Clutch body locking plate
11. Fitting tool for snap ring on crankshaft
12. Fitting tool for snap ring on crankshaft.
13. Extractor for roller bearing
14. Extractor for roller bearing
15. Driving tool for shaft seal on left crankshaft
16. Driving tool for shaft seal (telescopic fork)



9.4 Ordering spare parts

For your MAICO-machine use only genuine MAICO spare parts as there will be no more warranty when using parts of other manufacturers. Always order at your appropriate MAICO-dealer.

When ordering always state the computer no., exact description, quantity and kind of dispatch so that a fast and trouble-free delivery is guaranteed.

9.5 Service instructions after 20 minutes run

1. Check all the screws and nuts for fixed position. If they are not fixed, tighten them according to torques in chapt. 2.2.5.
2. Centre again spokes at front and rear wheel. The spokes must be tightened properly and equally. Spray lubricant onto spoke nipples before tightening.
3. Tension the chain as a new chain is lengthening after the first run very much. Adjust chain slack. (s.chapt.3.5 assembling rear wheel). Centre rear wheel brake at the same time.

9.6 Service instructions after one hour run

1. Exchange transmission oil (BEL RAY MC 4)
2. Exchange telescopic fork oil (BEL RAY LT 100/LT 200)
3. Clean air filter and rub out properly air filter cage with a cloth. Oil air filter with BEL RAY MC6
4. Oil motorcycle at all parts which are to be lubricated
5. The same service as in chapt. 9.5.

9.7 Service instructions after 10 hours run

1. Exchange primary chains
2. Exchange drive oil
3. Exchange telescopic fork oil and transmission oil
4. Remove and clean main tube and assemble it when greased
5. Clean needle bearing in swing arm and assemble it when greased
6. Check all cables
7. Check brake lining.



9.8 Preparation for the race

1. Grease cables (with BEL RAY MC 22)
2. Clean air filter and oil it with BEL RAY MC 6)
3. Check air pressure in telescopic fork
4. Check air pressure in tyres
5. Check spring pretension of shock absorbers
6. Adjust play of brakes and clutch
7. Check tyres for sufficient edges at the lugs
8. Check for correct carburetor adjustment
9. Check chain slack
10. Grease chain
11. Retension spokes at front and rear wheel
12. Check all screws and nuts for tightness
13. Check steering head for play

Lubrication

1. Chain
2. Cables
3. Brake and clutch lever at handlebars
4. Foot brake lever
5. Brake key front and rear
6. Foot rests
7. Kickstarter hinge
8. Shock absorbers at spring guide ring

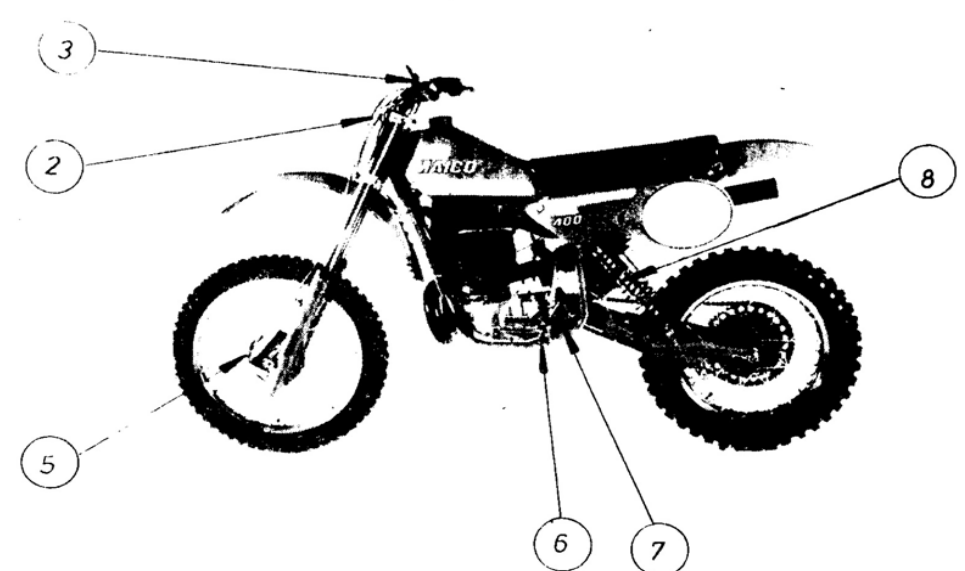
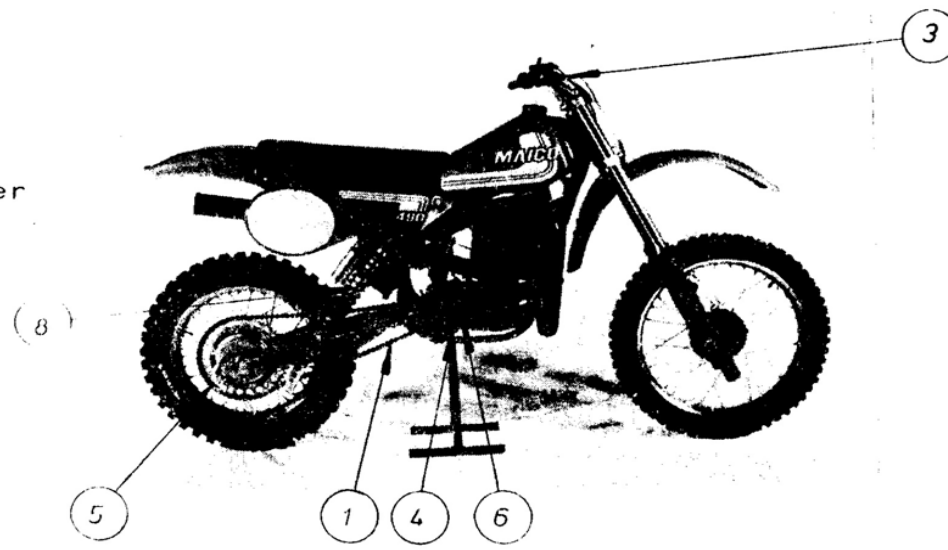

10. Trouble diagnosis10.1 Trouble diagnosis (electricity)

Symptom	Cause	Remedy
Engine fails to start	defect spark plug	Screw out spark plug and check for spark
	poor connection at ignition coil	press connections together so that they are fixed
	high tension lead is burnt at exhaust	replace high tension lead
	faulty ignition coil or ignition system	exchange ignition coil and ignition system separately so that defect part can be found
	faulty spark plug connector	dry with cloth

Carburetor and fuel

Engine fails to start	no fuel in tank	refuel
	ventilation in gas tap is blocked, therefore no fuel inflow	blow through ventilation with compressed air
	carburetor jets blocked so that fuel can't flow	clean carburetor and jets

Electricity

Engine runs unevenly	faulty ignition system possible	replace spark plug or replace ignition coil and ignition system separately and replace faulty part
	incorrect ignition timing	check and adjust when necessary
	faulty shaft sealing ring on right crank-case part	replace shaft sealing ring



Symptom	Cause	Remedy
Engine runs unevenly	carburetor adjustment incorrect	adjust carburetor (see chapt. 7.0)
	leaking cylinder head or cylinder base gasket	replace defect gasket
	too much oil in fuel	leaner mixture MAICO-oil 1:100
	defect shaft sealing ring for crankshaft left side	replace shaft sealing ring
Engine runs after	incorrect carburetor adjustment	adjust carburetor
	defect rubber between carburetor and cylinder	replace rubber
	engine gets wrong air	
Overheated engine piston is seizing	defect cylinder base gasket	replace gasket
	lubrication brakes down	richer mixture
	wrong spark plug with heat range too low	replace spark plug (higher heat range)
	ignition adjustment incorrect	adjust ignition correctly
	carburetor adjustment too lean	adjust carburetor (see chapt. 7.0)
Too much engine noise and vibration	engine fixing loose	tighten
	exhaust fixing loose	tighten
	exhaust touches frame	correct it by spacer washers at the fixings
	exhaust is cracked	disassemble and weld replace if necessary

10.2 Trouble diagnosis clutch

Engine speed en-creasing without velocity increase	clutch slips	check adjustment of clutch
	diaphragm springs too soft	replace diaphragm springs
	uneven inner discs	replace uneven inner discs



Symptom	Cause	Remedy
Difficult to change gears. Noises when changing gears. Engine is moving when clutch is engaged.	clutch doesn't release	adjust play at hand lever
	clutch adjustment has too much play	adjust play at hand lever
Neutral position difficult to find.		
Clutch is moving heavily.	defect, clamped or frayed out clutch cable	check clutch cable and insert it without bents

10.3 Trouble diagnosis transmission

Transmission gears fail to shift smoothly	deformed shift fork	replace
	gear change lever touches housing cover	replace
	worn pawl pin	replace
	spring of pawl pin clamps	insert new spring
Gears disengage accidentally	worn clutch plates at gear pinions	replace pinions
Gear change lever fails to return	broken gearshift return spring	replace
Engine fails to shift easily	bent gear change crank	align or replace gear change crank
Kickstarter lever fails to return	return spring not enough pretensioned or broken	pretension or replace spring
Kickstarter slips down	worn shifting segment, worn ratchet wheel or pinion	replace worn parts

